

5. Alignment and Adjustments

5-1 When Entering Service Mode:

1. Enter the service mode by pressing the remote control keys in the following sequence :

Mute -> 1 -> 8 -> 2 -> Power On

Note : If necessary, re-do steps 1~3.

2. Initial display when the service mode is switched to below OSD



3. Service Mode Control Key

Main Menu	Menu Display
CH UP/DOWN	Select item by moving cursor
VOL UP/DOWN	Decrease or increase the adjustment values

4. Factory Data :

1) DDP1010

	ITEM	ADRESS	MIN	MAX	DEFAULT	DESCRIPTION
1	POS-Y	0xEC	0	31	16	First Valid line in frame
2	POS-X	0xEC	0	511	147	First active pixel in line
3	LAMP	0x24	1	2	2	1:OSRAM, 2:TOSH/PHIL
4	DELAY	0x21	0	359	223	Color wheel index delay calibration value
5	V-FLIP	0x3	0	1	1	Vertical Flip Operation

6	H-FLIP	0x3	0	1	1	Horizontal Flip Operation
7	GAMMA	0x09	0	15	4	GAMMA Value Selection

2) DNIe : ALL

	ITEM	ADRESS	MIN	MAX	DEFAULT	DESCRIPTION
1	R_GAIN	0x2B1	0	255	120	Red_Gain control
2	G_GAIN	0x2B1	0	255	120	Green_Gain control
3	B_GAIN	0x2B2	0	255	120	Blue_Gain control
4	R_OFFSET	0x2B2	0	255	128	Red_Offset control
5	G_OFFSET	0x2B3	0	255	128	Green_Offset control
6	B_OFFSET	0x2B3	0	255	128	Blue_Offset control
7	SYNC_MODE	0x211	0	1	1	SYNC_MODE selection
8	RAST_H	0x215	0	2047	1504	H_SYNC Value
9	PROC_SET	0x220	0	255	PC / DVI: 0x44 RN : 0x66	SNI enable / disable selection
10	PATT_SEL	0x230	0	14	0	SNI Pattern select
11	KNOB_RED	0x280	0	2047	91	Slope value selection (when input Cb is positive number)
12	KNOBBLUE	0x281	0	2047	91	Slope value selection(when input Cb is negative number)
13	C_SEL	0x298	0	1	RF : 0 RN : 1	C-A daptation application select
14	S_BR(DDP)	0x00	0	255	DVI : 254 COM : 252 PC: 253 RF : 247	DDP1010 sub_Brightness adjust
15	S_CT(DDP)	0x01	0	511	DVI : 106 COM : 118 PC : 107 RF : 135	DDP1010 sub_contrast adjust

3) AD9883 : COMPONENT 2,3, 480P

	ITEM	ADRESS	MIN	MAX	DEFAULT	DESCRIPTION
1	Y-GAIN		0	255	150	Red_Gain control
2	Y_OFFSET		0	127	60	Red_Offset control
3	CR_GAIN		0	255	150	Green_Gain control
4	CR_OFFSET		0	127	58	Green_Offset control
5	CB_GAIN		0	255	150	Blue_Gain control
6	CB_OFFSET		0	127	58	Blue_Offset control
7	AUTOCOLOR					DTV Auto color
8	AD_RESET					

4-1) VPC3230 (RF ~ S VIDEO)

	ITEM	ADRESS	MIN	MAX	DEFAULT	DESCRIPTION
1	BR_M	0x52	0	255	152	Main Bright Adjust
2	CT_M	0x53	0	63	36	Main Contrast Adjust
3	SAT_M	0x30	0	4090	1900	Main Saturation Adjust
4	TINT_M	0xDC	0	255	132	Main Tint value setting
5	RFS_M	0x53	0	2	2	Main Horizontal Peaking Filter Selection 0 : broad, 1 : med, 2 : narrow
6	PK_M	0x53	0	7	2	Main Peaking Gain Selection
7	PKCOR_M	0x53	0	1	1	Main Peaking Coaring ON/OFF
8	BR_S	0x52	0	255	152	Sub Bright Adjust
9	CT_S	0x53	0	63	36	Sub Contrast Adjust
10	SAT_S	0x30	0	4090	1900	Sub Saturation Adjust
11	TINT_S	0xDC	0	255	132	Sub Tint value setting
12	PFS_S	0x53	0	2	2	Sub Horizontal Peaking Filter Selection 0 : broad, 1 : med, 2 : narrow
13	PK_S	0x53	0	7	2	Sub Peaking Gain Selection
14	PKCOR_S	0x53	0	1	1	Sub Peaking Coaring ON/OFF
15	IFC_M	0x21	0	3	2	bit[4:4] IF compensation
16	CBW_M	0x21	0	3	3	bit[6:5] chroma bandwidth selector 00 narrow, 01 normal 10 broad, 11 wide

18	LPF2_M	0x52	0	3	0	bit[9:8] horizontal lowpass filter for Y/C 0 bypass, 1 filter 1 2 filter 2, 3 filter 3
19	CBW2_M	0x21	0 0	1	0	bit[10] horizontal lowpass filter for high-resolution chroma 0/1 bypass/filter enabled
20	IFC_S	0x21	0	3	2	Sub IF compensation
21	CBW_S	0x21	0	3	3	Sub chroma bandwidth selector
22	LOWP_S	0x21	0	1	1	enable Sub luma lowpass filter
23	LPF2_S	0x52	0	3	0	Sub Horizontal LPF for Y/C
24	CBW_S	0x52	0	1	0	Sub Horizontal LPF for Chroma

4-2) VPC3230 (480i)

	ITEM	ADDRESS	MIN	MAX	DEFAULT	DESCRIPTION
1	BR_M	0x92	0	255	191	Main Bright Adjust
2	CT_M	0x92	0	63	31	Main Contrast Adjust
3	SATCB_M	0x90	0	63	38	Main Saturation_Cb Adjust
4	SATCR_M	0x90	0	63	40	Main Saturation_Cr Adjust
5	TINT_M	0x91	0	63	32	Main Tint value setting
6	IFC	0x21	0	3	0	IF compensation
7	CBW	0x21	0	3	3	chroma bandwidth selector
8	LOWP	0x21	0	1	1	enable luma lowpass filter

5) JaguarADC : PC

	ITEM	ADDRESS	MIN	MAX	DEFAULT	DESCRIPTION
1	R_GAIN	0xf8	0	255	128	R_GAIN Adjust
2	R_OFFSET	0xf9	0	255	64	R_OFFSET Adjust
3	G_GAIN	0xfa	0	255	128	G_GAIN Adjust
4	G_OFFSET	0xfb	0	255	64	G_OFFSET Adjust
5	B_GAIN	0xfc	0	255	128	B_GAIN Adjust
6	B_OFFSET	0xfd	0	255	64	B_OFFSET Adjust
7	AUTOCOLOR					Jaguar ADC Autocolor

6) FLI2300 : RF, VIDEO, 480I

	ITEM	ADDRESS	MIN	MAX	DEFAULT	DESCRIPTION
1	CT	0x302	0	255	138	Contrast Adjust
2	BR	0x303	0	255	128	Brightness Adjust
3	SAT	0x304	0	255	177	Saturation Adjust
4	LOW_FREQ	0x16E		255	32	Set motion threshold for low frequency signals. Defines the lower limit of low frequency motion, below which motion is not detected
5	HIGH_FREQ	0x16F	0	255	88	Contains motion threshold for high frequency signals
6	MULTI_MTN	0x170	0	255	56	Contains motion threshold for multiburst signals
7	Y_BR	0x34E	0	2046	1023	Contains the 2s complement brightness control parameter for Y/G data
8	CB_BR	0x350	0	2046	1023	Contains the 2s complement brightness control parameter for Cb/B data. Set to 0x000 for CbCr.
9	CR_BR	0x352	0	2046	1023	Contains the 2s complement brightness control parameter for Cr/R data. Set to 0x000 for CbCr.
10	NR	0x130 bit[6]	0	1	1	Noise reducer bypass control 0 = Noise reduction on 1 = Noise reduction off



7) 3D_COMB : ALL

	ITEM	ADDRESS	MIN	MAX	DEFAULT	DESCRIPTION
1	DYCOR	0x04	0	15	1	Y motion detection coning bit [7,4]
2	DYGAIN	0x04	0	15	10	Y motion detection gain bit [3,0]
3	DCCOR	0x05	0	15	2	Y motion detection coning bit [3,0]
4	DCGAIN	0x05	0	15	10	Y motion detection gain bit [3,0]

8) OPTION : ALL

	ITEM	MIN	MAX	DEFAULT	DESCRIPTION
1	AUTOPOWER			off	AUTO POWER ON/OFF Power ON/OFF
2	EER_RESET				EEPROM RESET
3	WBCONTROL			on	White Balance Control
4	COLOR			on	Color on/off
5	DVCO				Digital VCD Adjust
6	WBDEFSET			off	White Balance Setting
7	USERRESET				User Reset
8	LAMPLIFE				Lamp time display
9	LAMPCLEAR				Lamp time clear
10	MUTE_TIME	0	255	700	Tuning mute time selection
11	FAN_NUM	2	3	3	FAN Number selection

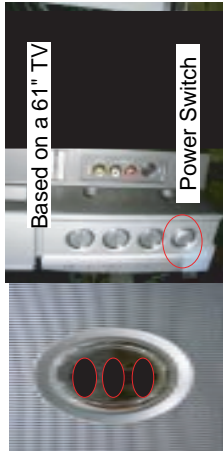
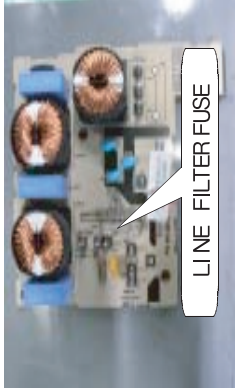
5-2 Contents Failure Repair Methods

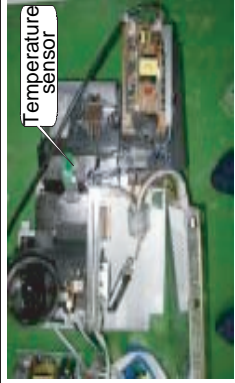
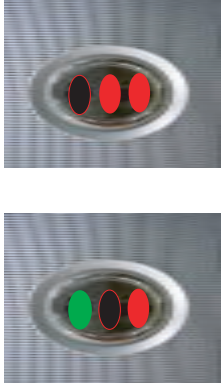
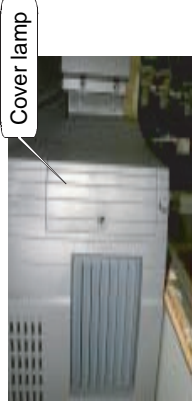

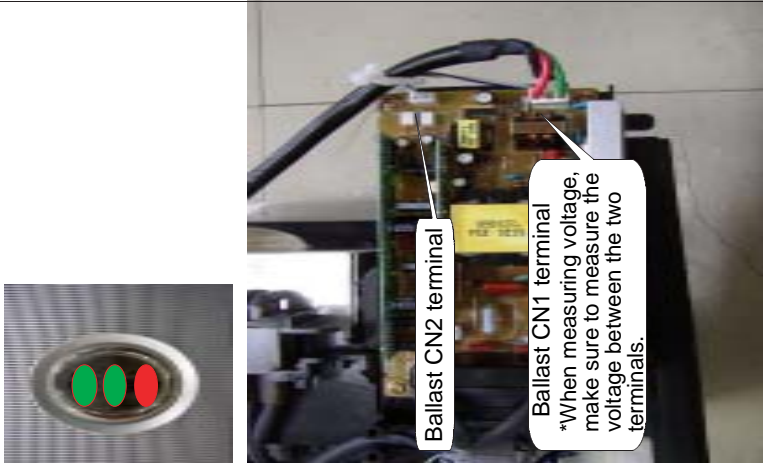
No.	Item	Picture	Description	Remarks
	Normal operation [LED Status]		<ol style="list-style-type: none"> When the power cord is plugged in and the power switch on the right of set is pressed ----- The red LED indicator should be lit. (Domestic) When the power cord is plugged in, the LED indicator is not lit. (Overseas) When the set is turned on via the remote control, the Lamp LED indicator at the center is lit. When the timer setting function is used, the Menu LED indicator at the top is lit. 	<ol style="list-style-type: none"> Flickering of the Lamp LED indicator means that the lamp is about to be turned on. The ON state of the Lamp LED indicator means that the lamp has been turned on.
	Failure Type	Picture	Inspection Items	Remarks
1	When the Domestic Power LED indicator does not light up.		<ol style="list-style-type: none"> Check whether or not the power cord is connected. Check whether the power switch on the right of set has been pressed. Check the line filter fuse. Check the connections of the ANALOG CN111 and CN511 connectors. Check the connection of the DIGITAL CN307 connector and check whether LED indicator OP301 (one) is lit. Check the connection of the DIGITAL CN303 connector and check whether 5V power has been supplied to pin #5. 	
	When the Abnormal Temperature LED indicator flickers.		<ol style="list-style-type: none"> Check whether the temperature sensor connector attached to the engine has been inserted normally into CN305 on the DIGITAL board. Check whether the temperature sensor is normal when both terminals have been short-circuited (connected). 	
	Timer+ standby/ LED blinking at abnormal temperature Power/LED blinking at abnormal temperature		<ol style="list-style-type: none"> Check that the fan operates when LED for timer, standby or abnormal temperature blinks. Check that the cover detection switch is inserted at CN310 on the digital board when LED for timer, standby or abnormal temperature blinks. When LED for timer, standby or abnormal temperature blinks, check that the lamp cover is properly assembled and that the switch-pressing boss(inside) is not bent. 	

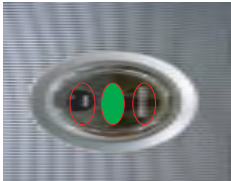
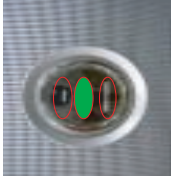
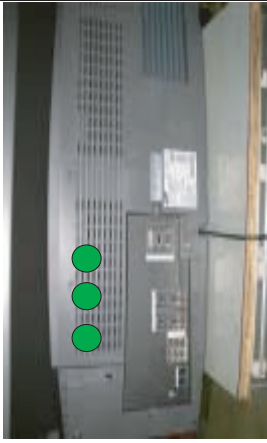
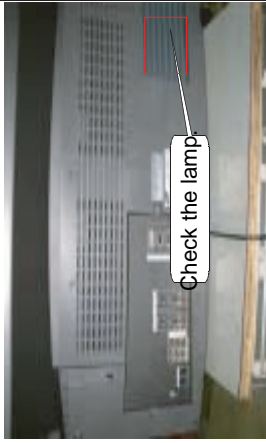
No.	Item	Picture	Description	Remarks
1	<p>When the Timer, Lamp, and Abnormal Temperature LED indicators flicker simultaneously.</p>		<p>1. If the 3 LED indicators flicker from the time the set is turned on, it means:</p> <ol style="list-style-type: none"> 1) The CN106 connector on the DMD board is not inserted properly. 2) The MDR cable that connects the DIGITAL board to the DMD board is not connected properly. 3) If the lamp does not turn on even after turning it on three times, by powering off/on 15 second intervals: <ol style="list-style-type: none"> ① The B+ 380V power is not supplied to the ballast (The cable is not connected properly between the power and the ballast.) ② The cable connected to the CN110 terminal on the DMD board and the CN2 terminal on the ballast is short-circuited or not connected. ③ The lamp does not turn on because 5V has not been supplied to blue pin #1 on the CN2 terminal of the ballast. ④ 5V is supplied to the CN2 terminal on the ballast but the lamp does not turn on because the ballast has a failure. (If the lamp is replaced and 5V is supplied normally to the CN2 terminal, suspect a ballast failure if the lamp still does not turn on.) ⑤ The ballast is normal but the lamp does not turn on. (When 5V is supplied to CN2 and 385V to CN1, but the lamp does not turn on, try replacing the lamp. If it turns on, that means it was a lamp failure.) 4) The color wheel engaged to the engine does not operate, or the connector which indicates the operation of the color wheel is not connected properly, and therefore does not allow the lamp to turn on. The cause can be determined when the set still does not turn on after attempting to turn it on three times. 5) Another digital board or the DMD board has a failure. Conclusively, if the three LED indicators flicker, first check the above five items, then check the various connector connections, and then suspect a failure of the lamp or the ballast. 	

No.	Item	Picture	Description	Remarks
1	The set is normal		<p>1) Means that the lamp is turned on normally.</p> <p>* Description of LED indicator operations</p> <p>① The Lamp LED indicator flickers while turning on the lamp.</p> <p>② The mechanism is designed in such a way that if three turning-on trials (with 15 second intervals between each trial) fail, the set should be powered off (reset) and then three turning-on trials should be tried again.</p>	
	Failure Name		Failure if the LED indicator is normal but the screen is not displayed.	
2	First		Only the Lamp LED indicator should be turned on.	
	Second	Check whether the DIGITAL board LED indicators inside the set are lit.	<p>All of the three LED indicators should be turned on.</p> <p>* You can observe those LED indicators through the cabinet holes at the back of the set. All three LED indicators should be turned on.</p>	
	Third	Check whether the set lamp is turned on.	<p>When the lamp is turned off, replace it.</p> <p>* When you turn on the set again after replacing the lamp, - It should turn on within 30 seconds. (For 50 and 61 inch TVs)</p> <p>* If more than one minute passes before it turns on, or if it does not turn on, replace both the ballast within the engine and the lamp.</p>	

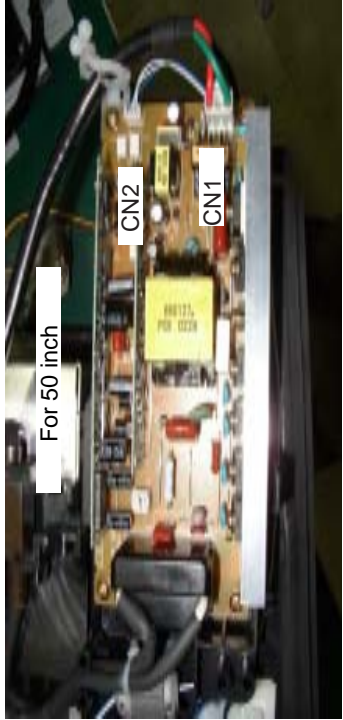
	<p>Fourth [Lamp replacement]</p>	<p>Remove the cover lamp screw as shown in the figure below.</p> 	<p>Remove the screws on both sides of the lamp.</p> 	<p>Pull the lamp out while holding its knob, and then replace it with a new one.</p> 	<p>Lastly, assemble the cover lamp. Check whether the new lamp turns on.</p> <p>The screen should be turned on.</p>
	<p>Fifth [Ballast operation check]</p>	<p>Open the back cover of the set and short the protection switch.</p> <p>Press the switch to cause a short.</p>  <p>On the right side of the back of the set.</p>	<p>Check whether the power and the lamp enable signal have been supplied to the ballast.</p>  <p>1. Check whether 5V is supplied to the blue terminal of CN2 2. Check whether DC 380V is supplied to both end terminals of CN1</p>	<p>Repair plan</p> <p>1) If 5V is applied to the CN2 terminal of the ballast, but the lamp does not turn on, replace the ballast. 2) When 5V is not supplied, replace first the engine. If the lamp still does not work, replace the DMD board attached to the engine.</p> <p>* For repair methods of the DMD board, refer to separate instructions.</p>	
<p>Sixth [The lamp is normal, but a blank screen failure occurs.]</p>	<p>Check the signal supply procedure. [Check whether the signals are supplied from the analog board to the digital board]</p> <p>1) Check in which mode the screen does not display. 2) If the RF, VIDEO, DVD, or DTV mode screen does not display, check the Analog CN511 terminals, Digital CN309 connector connections, and their signaling. 3) If the DVI or PC mode screen does not display, replace and inspect the digital board. 4) If the screen does not display in any mode, check whether the signals are being output from the digital board.</p>	<p>Method for inspecting whether signals are being supplied from the digital board to the DMD board</p> <p>Check the output of the IC314 terminal. If the signal output state is normal, suspect the DMD board.</p> <p>* Refer to the Digital Board Description Diagram.</p>	<p>DMD board inspection method</p> <p>1) Check whether +26V and -26V is being supplied to the DMD board. -> If the voltage is abnormal, replace the tantalum condenser (C116, C110: When failure occurs intermittently.) If the problem continues after replacement, then replace the power drive IC (IC108). 2) If the DMD voltage is normal, replace the panel, or reassemble the panel. (Try to fix the four silver screws again.)</p> <p>* Refer to the DMD Board Description Diagram.</p>		

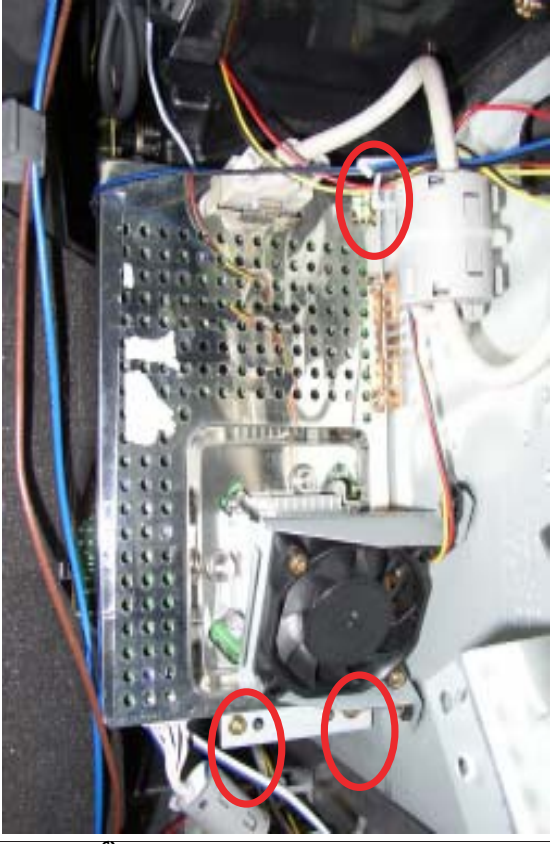
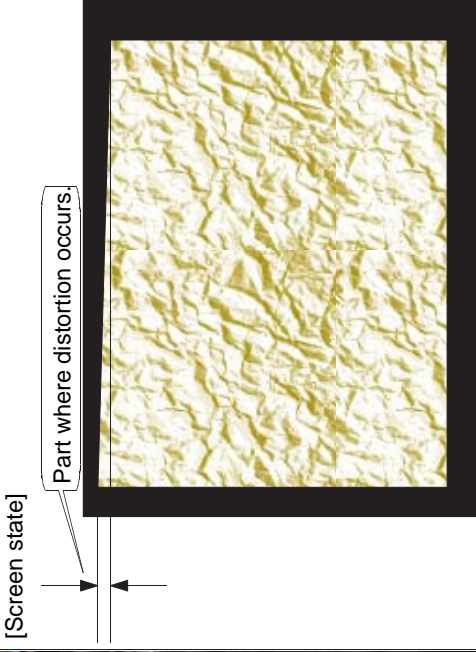
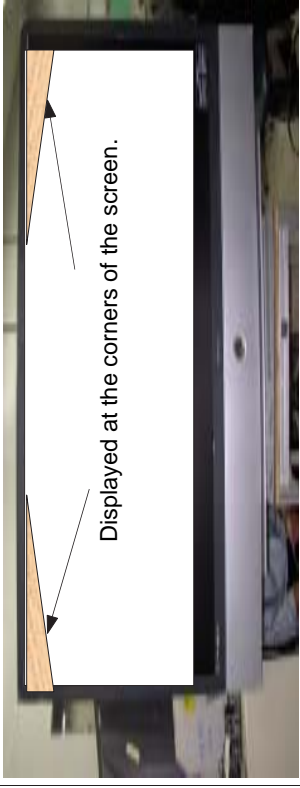
2	<p>Seventh [DMD state inspection method]</p>	<p>Remove the heat sink attached to the DMD board and follow the directions given below. 1) Replace the heat sink. Fix the DMD by tightening the screws again. 2) Check signaling for each part.</p> <p>* Refer to the DMD Panel PIN Terminals Characteristics Diagram.</p>	<p>Horizontal raster failure occurs. [Check whether the output of the R NETWORK RA101~RA104 terminals of the DMD board are normal.]</p> <p>* Refer to the DMD Board Description Diagram</p>	<p>Vertical line failure occurs. * Check whether it occurs within the regular wide range. (Less than 26mm for 50-inch TV)</p> <p>1) If it appears at regular intervals of less than 26mm, check the DMD fixing state. → Loosen the four silver screws and then re-assemble them. 2) If the vertical lines do not occur at regular intervals, or the intervals are more than 26mm, or irregular, replace IC117 (DDP1010).</p>	
3	<p>Noise failure</p>	<p>Check the noise state of the color wheel. 1) If the noise of color wheel is loud, replace the engine or the color wheel. 2) When the color wheel is replaced, make sure to adjust the delay value of 1.DDP1010 to factory settings. (Adjust to the position where the color red is strongest.)</p>  <p>The color wheel is attached as shown in the following figure. Loosen the screws which fix the outer parts and then replace the color wheel.</p>	<p>Fan noise 1) Check the revolving state of the fan to inspect whether the fan wire is caught on the wings, then check the bearing noise.</p> <p>50-inch: Two fans 61-inch: Three fans</p>	<p>Ballast noise 1) Check whether there is noise from the ballast, if noise is too loud, replace the ballast.</p>	

<p>4</p>	<p>Loosen the three screws as shown in the following figure and then adjust the DMD board by turning it to the left, right, up, or down. * For factory settings, set the POS-X & the POS-Y values of DDP1010 to the center.(16/147) 1) Separate the digital board. 2) Loosen the three screws shown in the following figure and then perform the image adjustment.</p> 	<p>If the lower part of image is well aligned horizontally but the upper part is not aligned horizontally (PC mode is best for viewing.) 1) To repair the upper distortion failure, separate the screen and put an inlay into the buss of the cabinet back on the mirror fixing part.</p> 
<p>5</p>	<p>Failure state 1) Colors are mixed at the corners. 2) It checked-out okay while in the white pattern. (Lower part failure state)</p> 	<p>Repair procedure 1) Loosen the screw of the part as shown in the following figure. 2) Move the mirror so that there is no skipped color and then fix the mirror using UV bond.</p> 

No	Item	Repair procedure	
2	The screen does not display in a specific mode. [The screen is abnormal in the PC and DVI modes.]	Replace the PCB digital board ASSY.	
3	When the menu function of the TV or the OSD has a failure.	Replace the PCB digital board ASSY.	
4	Failure state	Check the color wheel noise state.	Check the fan noise state.
	Noise failure [Shoo is heard.]		
Factory adjustment state check items			
	Factory settings to check Description	Description	Remarks
5	POS-Y	Screen upper and lower adjustments	
	POS-X	Screen left and right adjustments	
	LAMP	Make sure to choose TOS/PHIL for 50-inch and OSR for 61-inch	
	DELAY	Terminal that controls the motor of the color wheel.	Adjust to the value where the color red is strongest. (Fix to the position where the degree of red is strongest in a red screen)
	V-FLIP	When the upper and lower portions of the screen are normal, it is normal	When the screen has reversed images, adjust to the normal state.
	H-FLIP	When the left and right portions of the screen are normal, it is normal.	When the screen has reversed images, adjust to the normal state.
	GAMMA	When the value is 4 it is normal. But, for the productions from July, 2002, it is normal when the value is 1.	Change the values to from 1 to 4 until the screen is not saturated and becomes normal. Set to the found value.

No.	Factory Item	Description	Remark	
6	R-GAIN	Red color adjustment for the high-light parts of the screen	Initial value: 120	
	G-GAIN	Fixed to 120		
	B-GAIN	Blue color adjustment for the high-light parts of the screen	Initial value: 120	
	R-OFFSET	Red color adjustment for the low-light parts of the screen	Initial value: 128	
	G-OFFSET	Fixed to 128		
	B-OFFSET	Blue color adjustment for the low-light parts of the screen	Initial value 128	
	Middle items: not relevant			
	S-BR(DDP)	Brightness adjustment for the low-light parts of the screen (RF: the initial value is 250.)	The value differs for DTV, PC, and DVI modes.	
	S-CT(DDP)	Brightness adjustment for the high-light parts of the screen (RF: the initial value is 135.)	The value differs for DTV, PC, and DVI mode.	
	R-GAIN	Red color adjustment for the high-light parts of the screen	Initial value: 255	
G-GAIN	Fixed to 230			
B-GAIN	Blue color adjustment for the high-light parts of the screen	Initial value: 255		
R-OFFSET	Red color adjustment for the low-light parts of the screen	Initial value: 128		
2.MN82860	G-OFFSET	Fixed to 120		
	B-OFFSET	Blue color adjustment for the low-light parts of the screen	Initial value: 255	
	Middle items: not relevant			
	S-BR(DDP)	Brightness adjustment for the low-light parts of the screen (RF: the initial value is 48.)		
	S-CT(DDP)	Brightness adjustment for the high-light parts of the screen (Initial value: 120)	The value for DVI mode is 108.	

No.	Factory Item	Description	Remarks
7.OPTION	AUTO POWER	The Default is OFF. When turned ON, the set turns on automatically when the power cord is plugged in.	
	EER-RESET	Clears the EEP-ROM.	
	WBCONTROL	The Default is ON. Performs screen color adjustment.	To perform color adjustment in a specific mode such as DTV or PC mode, select OFF and then adjust.
	COLOR	The Default is ON. Removes color when color adjustment is needed for broadcasted color bar signals.	
	DVCO	No specific function	
	WBDEFSET	Only when the software is to be replaced, set to ON and perform an EER-RESET in order to clear all items.	When performing an EER-RESET while turned ON, make sure to adjust the auto-color, image, and delay settings again.
	USERRESET	The last item that should be reset during the set shipment process.	
	LAMPLIFE	Time for which the lamp has been used.	
	LAMPCLEAR	Clears the lamp time and sets to "0". Used when shipping the set or replacing the lamp.	
	MUTE_TIME	Time which the screen will be black while switching channels.	
	DNle DEMO	Operational state of the DNle function	The models which do not have the DNle function do not have this item.
FAN NUM	50-inch has two fans and 61-inch has three fans. This item is used to identify it.		

Lamp/Ballast Management By Model	ballast	lamp	
61-inch	BP47- 00003A	BP96-00224B	* Make sure to use a lamp which is assembled with a case produced for apparatus projection. * Osram lamp ballast
43- or 50-inch	AA47- 00008A	BP96-00224A	* Toshiba lamp ballast

5-3 ASSY PCB ANALOG Service Manual

Characteristics of Terminals on ASSY ANALOG

CN510						
Terminal	Spec	Note	Terminal	Spec	Note	Usage
29	7VF	CN11#23	30	GND	CN11#24	Supplies power to PCB DIGITAL and receives PWR KEY from the PCB DIGITAL
27	12VD	CN11#17	28			
25			26			
23			24			
21	5VD	CN11#4,5,6	22	GND		
19			20			
17			18			
15	S-5V	CN11#27	16			
13	PWR	CN11#29	14			
11	R_MN	RESET	12			
9	SIG	A-MUTE	10			
7	SCL1		8			
5	SDA1		6			
3	SIG	A-SW	4	R_AN		
1	SIG	CHROMA2	2	C_SIG	DTV2	

ASSY PCB ANALOG (5BP94-00284A)

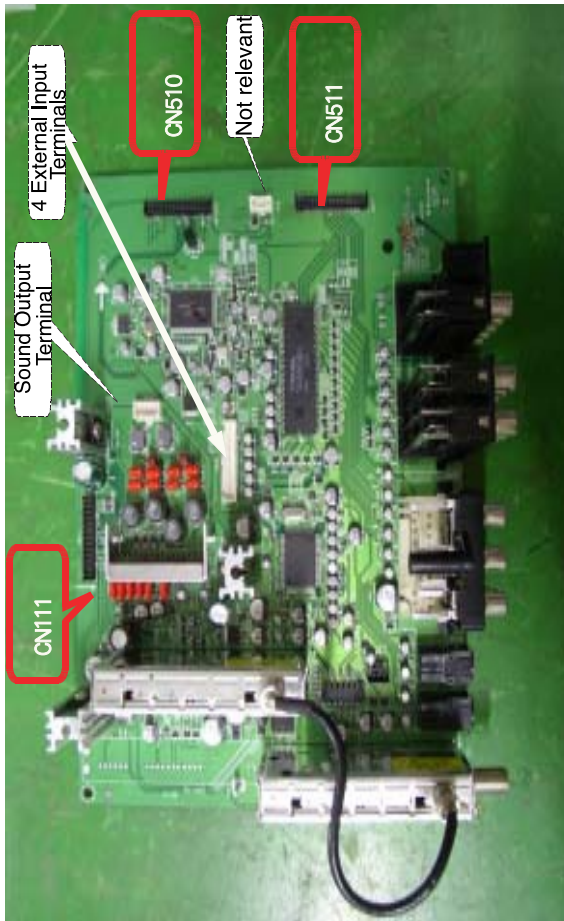

CN111															
Terminal	30	28	26	24	22	20	18	16	14	12	10	8	6	4	2
Spec	SMUT														
Terminal	29	27	25	23	21	19	17	15	13	11	9	7	5	3	1
Spec	PWR	S-5V	32VT	7VF	12VA	12VD	5VD	5VA	DC 5V	DC 18V					
Usage	Receives the power from the PCB power supply. Some of the supplied power is used for the PCB ANALOG, and some is used for the PCB DIGITAL.														

Note Since a failure may be caused due to improper insertion of the lead connectors into the analog board, make sure to inspect the contacts on the lead connector.

ASSY PCB ANALOG Terminal Spec Characteristics

ASSY PCB ANALOG General Characteristics	
1.	Receives general TV signals and supplies VIDEO (COMPOSITE) signals to the DIGITAL BOARD.
2.	Controls switching for and amplifies (IC104) all of the RF and sound signals, and outputs them to the speaker.
3.	The power is distributed from the POWER board through the ANALOG board to the DIGITAL board. Therefore, wrong insertion of the lead connector may cause a power failure. Make sure to insert the lead connector with the protrusions on the connector header placed in the right direction.
4.	If a blank screen failure occurs in the RF (general TV) mode and the ALL mode, first, check whether signals are supplied to the pins of the CN511 terminal on the Analog board, and then check whether normal signals are supplied to the Digital board and the DMD board.
5.	Mode switching failure between the TV/VIDEO1 and the PC mode may not be identified when connecting the jack if any of the IC101 PINs are short-circuited or IC itself has a failure.

ASSY PCB ANALOG (5BP94-00284A)

CN511				Usage
Terminal	Spec	Terminal	Spec	
31		32		Transmits the signals (RF/VIDEO/DVD/DTV) supplied from the PCB ANALOG to the PCB DIGITAL
29		30		
27		28		
25	Y	26		
23	Pb (DTV2 (COMP3))	24		
21	Pr	22		
19	Y	20		
17	Pb (DTV1 (COMP2))	18		
15	Pr	16	GND	
13	Y	14		
11	CB1 (DVD (COMP1))	12		
9	CR1	10		
7	RF/VIDE O1, 2,3 output	8	COMPOSITE	
5	Y-IN	6		
3	S-VIDEO 1,2,3 output	4	CHROMA-IN	
1	CVBS-CAP	2		

5-4 ASSY PCB DIGITAL Service Manual

ASSY PCB DIGITAL Characteristics

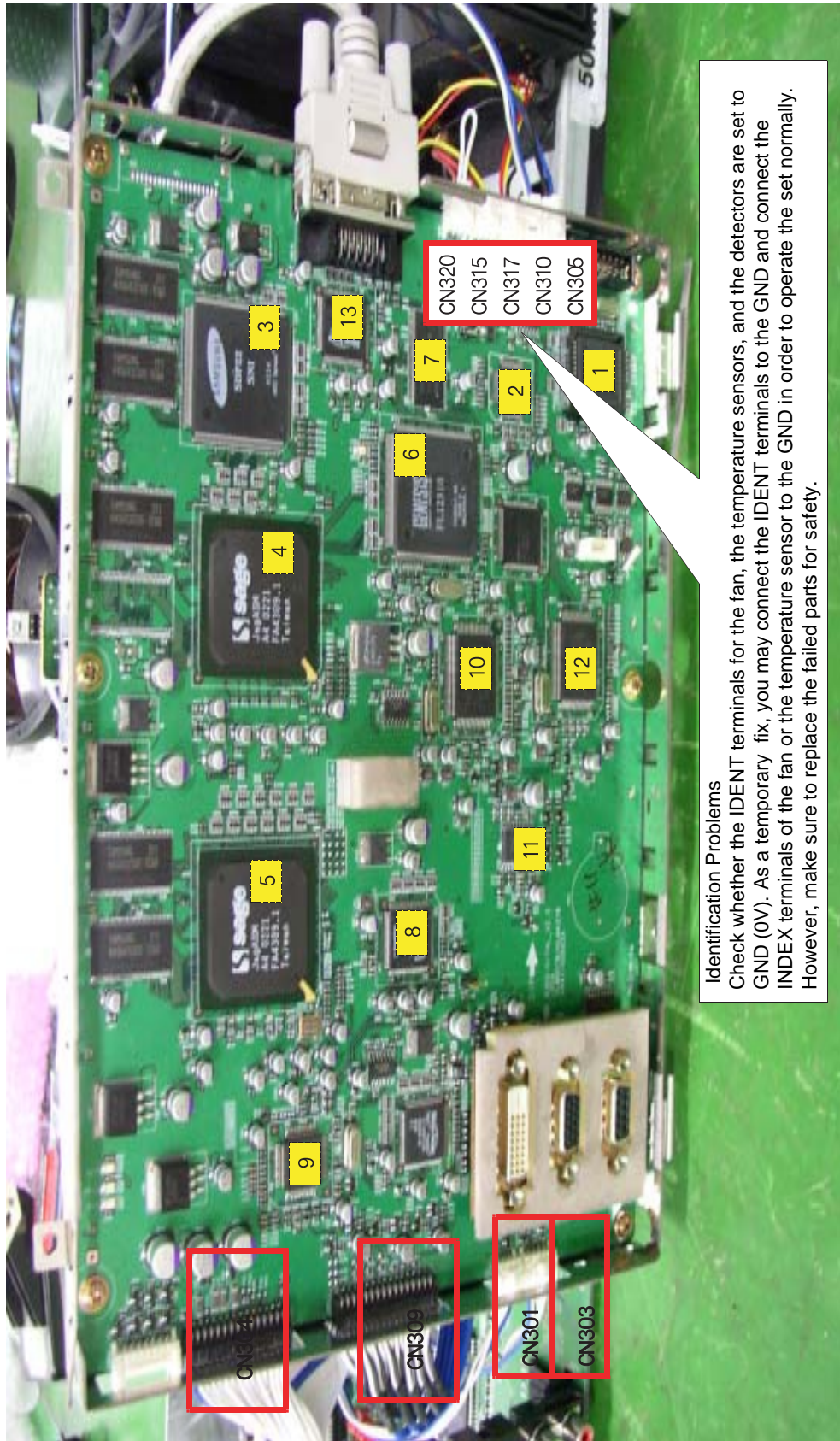

Identification Problems
 Check whether the IDENT terminals for the fan, the temperature sensors, and the detectors are set to GND (0V). As a temporary fix, you may connect the IDENT terminals to the GND and connect the INDEX terminals of the fan or the temperature sensor to the GND in order to operate the set normally. However, make sure to replace the failed parts for safety.

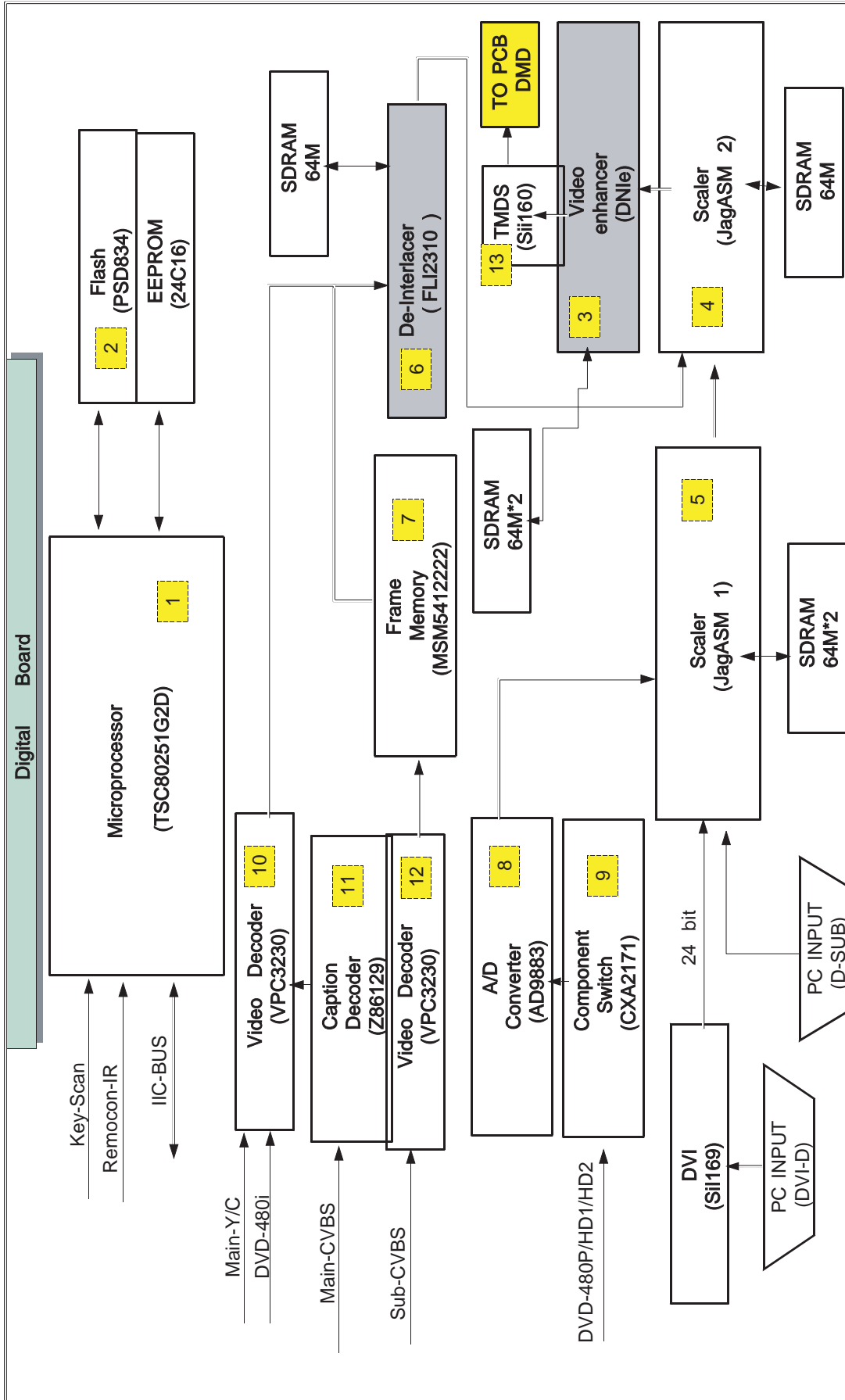

ASSY PCB DIGITAL Connector Characteristics

CN307				CN309				CN301		
Terminal	Spec	Terminal	Spec	Terminal	Spec	Terminal	Spec	Terminal	Spec	Remark
2	GNDF	1	7VF	1		1	S-5V	DC 5V		
4		3	12VD	3		3	GND	0V		
6		5		5		5	SIG	Pulse waveform for sending remote control signals (5V~GND)		
8		7		7	DTV2	7				
10	GND	9	5VD	9	(COMP3)	9	F7V (61": 8V)	FAN voltage supply		
12		11		11		11	GND			
14		13		13	DTV1	13	INDEX	5V:FAN stop, 0V:normal FAN operation		
16		15		15	(COMP2)	15				
18		17	S-5V	17		17				
20		19	PWR	19	DVD	19				
22		21	R_MN	21	(COMP1)	21				
24		23	SIG	23		23				
26		25	SQ_L1	25	RF/VIDEO1, 2,3 output	25				
28	R_AN	27	SIG	27	S-VIDEO	27				
30	C_SIG	29	SIG	29	1, 2,3output	29				
				31	COMPOSITE	31				
				32	Y-IN					
					CHROMA-IN					
					CVBS-CAP					
CN303										
1	GND	OV								
2	TEMP	When the set is set to HIGH (3V) before turning it on and then is turned on (3.4V), the output will fluctuate continuously between 3V to 3.4V if the temperature sensor has a failure.								
3	LAMP	While turning the set ON, the output will fluctuate between 3V and 3.4V before the lamp comes on. But, the 0V should be maintained after the set is turned on.								
4	TIMER	The output fluctuates between 3V to 3.4V whenever the remote control is pressed.								
5	S-5V	5V is maintained when inserting the power cord. 5V is still maintained after the set is turned on.								
CN305										
Terminal	Spec	Terminal	Spec	Terminal	Spec	Terminal	Spec	Terminal	Spec	Remark
1	Ident	1	Ident	1	Ident	1	Ident	5V: Abnormal temperature operation,		
2	GND	2	GND	2	GND	2	GND			
*If the internal temperature of the set increases, the temperature sensor is open and then the connection (short-circuit) between terminal 2 and the INDEX terminal is open to indicate abnormal temperature.										
CN310										
Terminal	Spec	Terminal	Spec	Terminal	Spec	Terminal	Spec	Terminal	Spec	Remark
1	Ident	1	Ident	1	Ident	1	Ident	5V:Back Cover Open		
2	GND	2	GND	2	GND	2	GND			
* If the back cover is open, the D/SWITCH is open between terminal 2 and the INDEX terminal (No. 1) to turn the set off.										

ASSY PCB DIGITAL Characteristics

OP301 (ON when the AC cord is plugged in.) S-5V	OP302 (ON after power on.) D5V	OP303 (ON after power on.) F7V	OP305
When the power cord is plugged in. STD-BY5V is supplied.	Base power for making 3.3V, 2.5V.	FAN voltage is supplied.	3.3V
The LED indicator should be lit when the AC cord is plugged in.	The LED indicator should be lit when the set is turned on via the remote control.		The modules should be turned on before operating the DNIE function. The modules should not turn on when the DNIE function is in operation .

ASSY PCB DIGITAL IC Characteristics

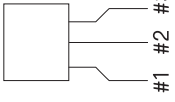
Item CODE	LOC NO	IC Characteristics	Output voltage	PIN#	PIN# 2	PIN# 3	PIN description
1203-001293	IC305	IC-POS I. FIXED REG .	3.3V		not	3.3V	
1203-002328	IC306	IC-POS I. FIXED REG .	2.5V		2.5V	5.0V	
1203-002328	IC307	IC-POS I. FIXED REG .	2.5V		2.5V	5.0V	
1203-001293	IC308	IC-POS I. FIXED REG .	3.3V	0V	not	3.3V	
1203-002056	IC309	IC-POS I. FIXED REG .	2.5V		5.0V	2.5V	
1203-001293	IC318	IC-POS I. FIXED REG .	3.3V		not	3.3V	
1203-001293	IC323	IC-POS I. FIXED REG .	3.3V		not	3.3V	
1203-001109	IC326	IC-VOL. D ETECTOR	5V/0V/5V	5.0V	0V	5.0V	
1203-002351	IC349	IC-VOL REGULATOR	2.5V	0V	not	2.5V	
Item No	LOC	Name	Spec				
0801-002171	IC317	IC-CMOS LOGIC	74LCX12 5.BUS BUFFER,SOP,14P,15				
0903-001202	IC337	IC-MICROCONT ROLLER	80251G2 , 8B it,P.LCC,44P , 653MIL,24MHz,T R,CMOS,PLASTIC,5V,1.5W,0 to+70C,1KB YTE,-,2 4Bi				
0909-001032	IC340	IC-REAL TIME CLOCK	8563,-,SOP,8P,15 3MIL,-32.768KHz,TP,CMOS,PLASTIC,3V,300mW,- 40to+85C,-,-,-,-,-				
1002-001292	IC320	IC-A/D CONVERTER	AD9883AKST-110,8BITS,Q.FP,80P,±0.5LSB,TR:CMO S,PLAS TIC,3.3V,- 25 TO+85C,6.50M				
1003-001503	IC347	IC-DISPLAY DRIVER	SNI,QFP,208P,28X28MM,- , 81MA,TR:PLAS TIC,2.5V,- 40TO+125C,-,4.6V,-				
1006-001076	IC338	IC-D RIVER/RECEIVER	232,SOP,16P,300MIL,DU AL,-S,T,PLA				
1103-000129	IC329	IC-EEPROM	24C02,256x8BIT,SO P,8P,150MIL,1				
1105-001336	IC301	IC-DRAM	4S643232,512Kx32x4Bit,TSOP,86P,400MIL,60nS ,3.3V,10%,P LAST IC,0 to+70C,2mA,CMOS,TP				
1107-001373	IC328	IC-FLASH MEMORY	PSD8 34F2-90M,2.56KX8BIT,PQFP,52P,10X10MM, 90NS,5V,10% PLAS TIC,0TO+70C,50 UA,CMOS,TP				
1109-001144	IC331	IC-FIFO	81V04160,2x256Kx8Bit,TQFP,10 0P,1414MIL,30 nS,3.3V,10%,P LASTIC,0 to+70C,3mA ,-,TR				
1203-001109	IC326	IC-VOL. D ETECTOR	7045,SOT- 89,3P,-,PLASTIC,4.3/4				
1203-001293	IC305	IC-POS I. FIXED REG.	033,TO -252,3P,6.5MIL,PLASTI C,3				
1203-002351	IC349	IC-VOL TAGE REGULATOR	LF25C,DP AK,3P,24 0MIL,PLASTI C,2.45V/2.55V,-,4 0TO+125C,-,2.85V/16V,TP				
1204-001388	IC330	IC-DECODER	Z86T29,SOP,18P,-,P LAS TIC,6 .0V,				
1204-001926	IC325	IC-VIDEO PROCESS	VPC3 230D-C5 ,P.QFP,80 P,-,PLASTI C,6V,-,0 TO 65C,TP,VPC3 230D-C5				
1204-001926	IC336	IC-VIDEO PROCESS	VPC3 230D-C5 ,P.QFP,80 P,-,PLASTI C,6V,-,0 TO 65C,TP,VPC3 230D-C5				
1204-002078	IC348	IC-VIDEO PROCESS	S2310,PQFP ,208P,28 X28MM,P LAST IC,3.6V,-, 40TO+10 0C,TR,DIGITAL VIDEO(ONLY)				
1204-002079	IC313	IC-SELECTOR	CXA2171Q,Q.FP,48P,12X12MM, PLAS TIC,5.25V,1400MW,- 20 TO+75C,TR, -				
1205-001778	IC314	IC-TRANSMITTER	SI1160C,T100,TQFP,100P,551MIL ,PLAS TIC,4V,1.0W,0 to+70C,TR,Digit al Transmitter				
1205-002028	IC310	IC-L0D CONTROLLER	JA GASM,BGA,3 88P,20 8MIL,PALAT IC,3.45V,2.5W , -40TO+12 5C,TR,DIGITAL DISPLAY PRO.				
1205-002028	IC311	IC-L0D CONTROLLER	JA GASM,BGA,3 88P,20 8MIL,PALAT IC,3.45V,2.5W , -40TO+12 5C,TR,DIGITAL DISPLAY PRO.				
1205-002198	IC322	IC-RECEIVER	SI1169CT100,LQFP ,100P,14 X14MM,PL ASTIC,3.6V,-,0TO+70C,TR,PANELLINK RECEIVER				

ASSY PCB DIGITAL IC Characteristics

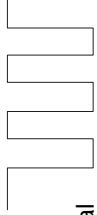
IC NAME	Characteristics	Remark
IC310 (JAGASM)	<ol style="list-style-type: none"> 1. Enables switching between VGA and UXGA modes. 2. Enables switching between 4:3 and 16:9 modes. (Used to change image size in COMPONENT 1, 2, 3, DVI and PC modes, which are externally input.) 3. Receives HDTV signals, which are MPEG2 signals. (Receives COMPONENT 1 (480P DVD), 2, and 3 signals, which are externally input.) 4. Directly interfaces the DVI digital signals to the IC314 (SILCOM IMAGE 161) receiver. 5. Performs auto adjustment. 	
IC311 (JAGASM)	<ol style="list-style-type: none"> 1. Enables switching between VGA and UXGA modes. 2. Enables switching between 4:3 and 16:9 modes. (Used to change image size in RF, PIP, and DVD (480i) modes, which are externally input.) 3. Supports OSD. 	
IC314 (TMDS)	<ol style="list-style-type: none"> 1. Scaleable Bandwidth 25~162 MHz 2. Low Power 3.3V 3. PIN 90~97: Even 8-bit red signaling 99~1~6: Even 8-bit green signaling 9~16: Even 8-bit blue signaling 48~55: ODD 8 BITS RED signaling (what's the difference between this and the next one in the list? Why is BITS RED capitalized?) 58~65: Odd 8-bit red signaling 68~75: Odd 8-bit blue signaling 4. 76:H-SYNC 77: V-SYNC operation check. * For inspection on the outputs of the end terminals, check the even bit terminal for each color (red, blue, green). 	 <p>* Even output terminal waveform No colored waveform is output. The odd terminal has no output waveform</p>
IC348 (FLI 2310)	<ol style="list-style-type: none"> 1. Performs DE_INTERLACING. 2. Receives inputs from 480i, 480P, 720P, 1080i, VGA, XGA. 3. Outputs to 480P, 720P, 1080i, 1080P, VGA, XGA. 	

5-5 ASSY PCB DMD Service Manual

DMD Board Schematic and Major Terminal Characteristics

ASSY PCB DMD (BP94-00475A)

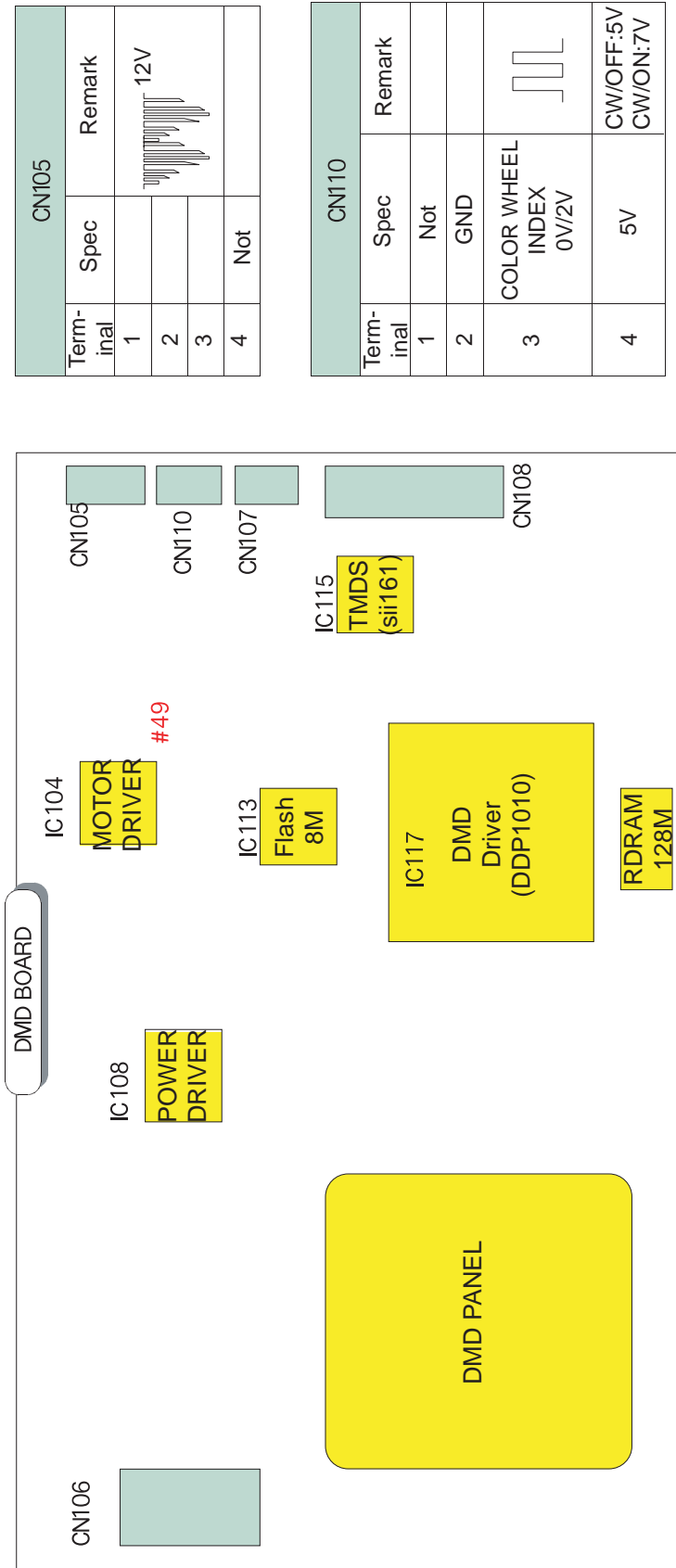

CN105		
Terminal	Spec	Remark
1		12V
2		
3		
4	Not	

CN110		
Terminal	Spec	Remark
1	Not	
2	GND	
3	COLOR WHEEL INDEX 0V/2V	
4	5V	CW/OFF:5V CW/ON:7V

CN107		
Terminal	Spec	Remark
1	SCI	Turns on the lamp.
2	GND	
3	LAMPL ITZ	H:LAMP OFF L:LAMP ON

IC NAME	Characteristics
IC108	* The power supply for operating the DMD. It generates +26V and -26V by using DC 3.3V and DC 12V and provides power to the panel. (If it does not generate DC± 26V, make sure to replace it.)
IC104	* The IC which drives the motor for the color wheel by using DC12V.

CN106								
Terminal	1	2	3	4	5	6	7	8
SPEC	DC 5V	DC 5V	DC 12V	DC 12V	GN	GN	Terminal	

DMD Board BLACK DIAGRAM

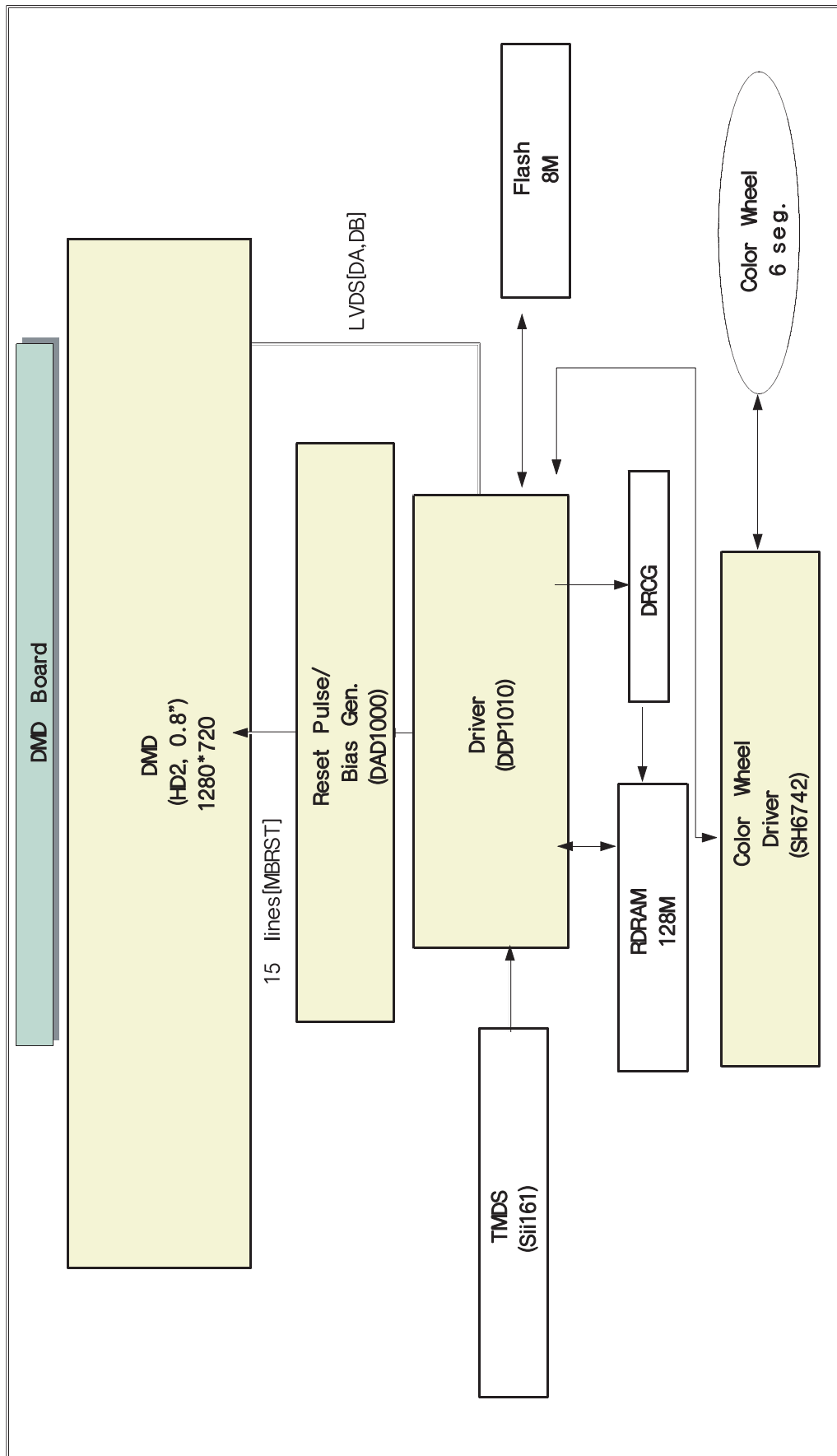

Output Voltage States of the DMD Board Parts

LOC.	Characteristics		
R166	LAMP EN	High from DDP1010	
R175	LAMP OUT	Outputs High signal. [SCI]	
R231	LAMPL ITZ	High (5 V) before the lamp turns on. Low (0V) when the lamp turns on.	

Description of Terminal Characteristics

PIN NAME	DESCRIPTION
SCTRL_BN/P	B channel LVDS serial control
DCLK_BN/P	B-channel LVDS CLOCK
SCPDI	SERIAL CONTROL DATA INPUT
SCPDO	SERIAL CONTROL DATA OUTPUT
SCPENB	SERIAL CONTROL ENABLE
SCPOK	SERIAL CONTROL CLOCK
DMD RESETB	DMD LOGIC RESET
MBRST(14:0)	MIRROR BIAS RESET
MBRST_EXTRA	UNUSED MIRROR BIAS RESET
SCR_CLR	TEST CLEAR PINS (NORMAL GND)
READOUTA(1:0)	A-CHANNEL SERIAL DATA OUT DURING SRAM READ TEST OPERATION
READOUTB(1:0)	B-CHANNEL SERIAL DATA OUT DURING SRAM READ TEST OPERATION
TP(2:0)	MANUFACTURING TEST POINT(NO CONNECTED DURING NORMAL OPERATION)
RSV_A(4:0) / RSV_B(4:0)	RESERVED PINS (NORMAL:GND)
EVCC	REFERENCE VOLTAGE DURING SRAM READ TEST OPERATION(NORMAL GND)
VCC2	MIRROR ELECTRODE VOLTAGE(7.3V)
VCC	LOGIC SUPPLY
VSS	LOGIC GROUND

Engine Failure Inspection Flow Chart for the DMD Board

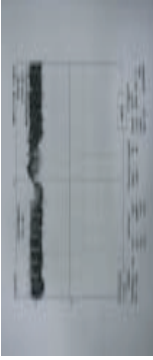
No.	Description	Key Point	Remark
1	1) When the power cord is plugged in, 2) DC 380V is automatically supplied to the ballast.	1) Check whether the DC380V power is supplied to the ballast.	* For domestic model, it is needed to check whether the master power switch is turned on. * The US model has no master power.
2	1) When the power key is pressed via the remote control, the micom of the digital board outputs high (5V) PWR signals. 2) The power board operates normally. 5V and 12V are supplied to the DMD CN106 terminal.	1) Check whether 5V and 12V are supplied to the CN 106 terminal.	* 12V must be supplied to operate the motor. (The voltage of the motor driving power is 12V.)
3	1) The MTR Reset signal is supplied to the R188 terminal of the motor IC104 from the micom on the digital board and then the motor starts to drive. 2) If the color wheel rotates for a certain time and then stops, check whether the color wheel sensor is normal. (Check the waveform on the No.2 terminal below CN110.) 	1) After the set is powered on, check whether 5V is detected on pin No.49 of IC104. * After a while, the sound generated by the rotating color wheel is heard.	* If 5V is not detected, the motor will not operate.
4	1) Check whether the signal (SCI: START CONTROL INPUT) that turns on lamp #1 of CN107 on the DMD board is high (5V).	1) Check whether CN107 #1 signal is 5V.	* When SCI is high (5V), the lamp litz of CN107 is low (0V). * CN107 #1 terminal voltage changes to pulse waveform 14 seconds after (for 50 inch TV) the time that the voltage is 5V. * When about 4 seconds have passed after changing to pulse waveform, the screens are displayed on the set.
5	1) Method for checking whether the DDP1010 IC RESET is normal.	1) If the voltage between R301 and R302 is 3V, it is normal.	
6	1) Check whether the signal and the voltage are output normally to the data line of DMD panel.	1) A waveform should be output on the data line. * Refer to the remarks.	

Lamp/TV On/Off Timing Chart & DMD Board Checkpoints

Based on the 50-inch TV.

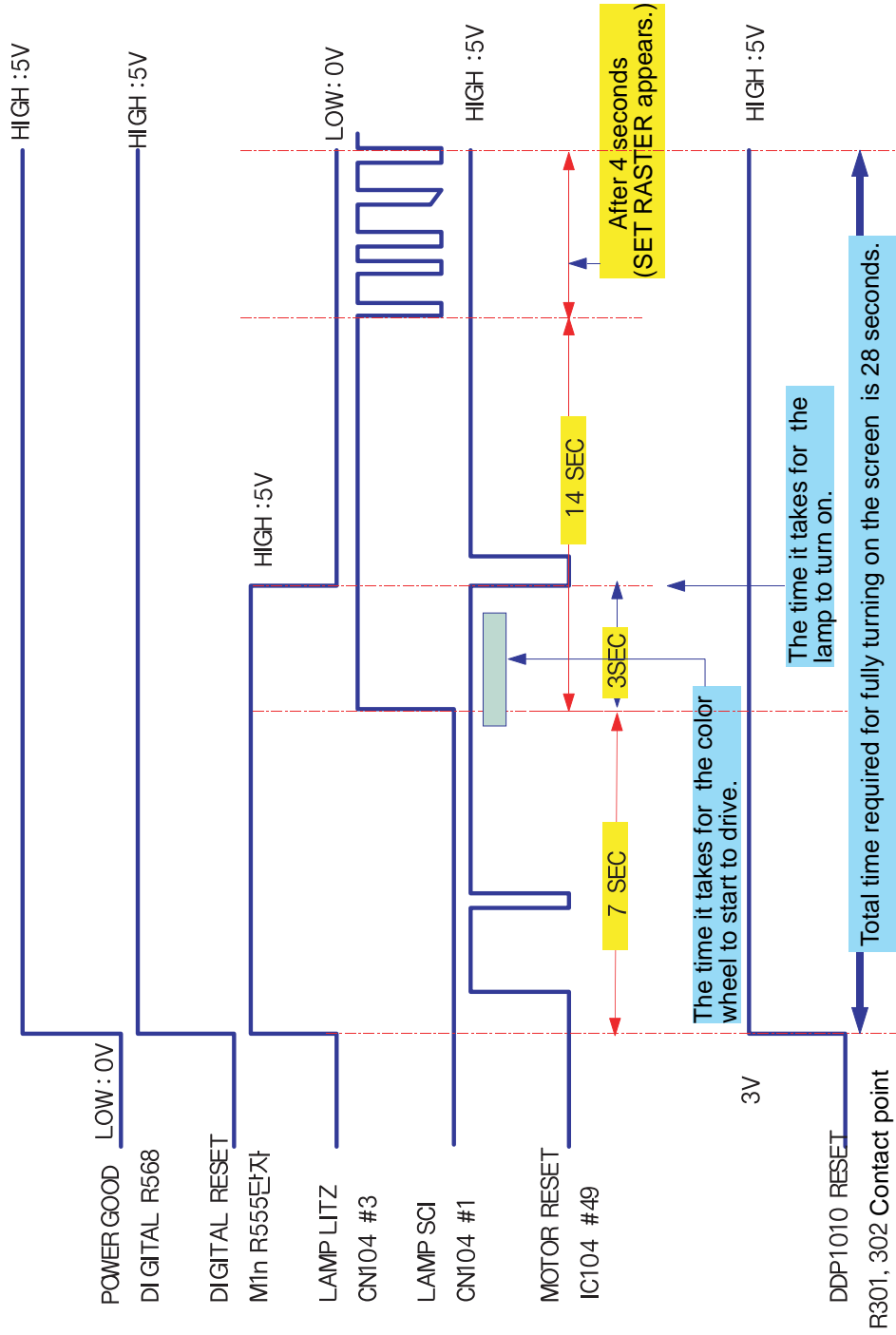

5-6 ASSY PCB POWER Service Manual

Description of the Characteristics of the Power Board Terminals

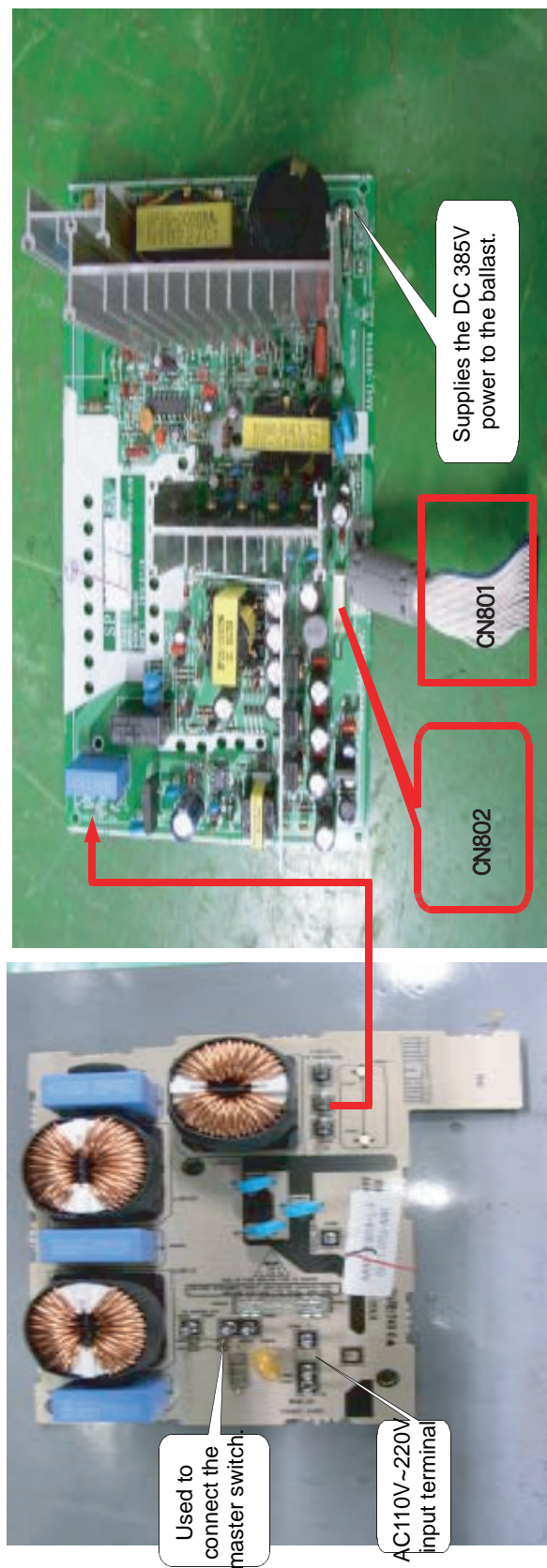

ASSY PCB LINE FILTER

CN802								
Terminal	1	2	3	4	5	6	7	8
Spec	DC-5V		DC 12V		GN Terminal			
Used	Supplies DC voltage to the PCB DMD							

ASSY PCB POWER

CN801																														
Terminal	15	14	13	12	11	10	9	8	7	6	5	4	3	2	1															
Spec	PWR	S-5V	32VT	7VF	12VD	12VA	12VD	5VD	5VA	DC5V		DC18V																		
Terminal	16	17	18	19	20	21	22	23	24	25	26	27	28	29	30															
Spec	SMUT		GND Terminal													GND Terminal														
Used	Supplies DC voltage to the PCB ANALOG and the PCB DIGITAL.																													

Reference: First, check whether power is supplied normally when high voltage (5V) is applied to terminal 15 of CN801, as for the power of the TV in general. Then, repair it, if necessary.

5-7 SERVICING AND CONTROLLING LAMP

SERVICING AND CONTROLLING LAMP (1/1)

1. How to control a lamp (time of application : Mar. 2003)

- Kinds of lamp used and method of indicating on lamp bracket (See the table below.)

Form of label on lamp	Classification														
<p>Label has a different background color depending on lamp.</p> <p>Form of label on lamp</p> <div style="border: 1px solid black; padding: 5px; margin: 5px 0;"> <p style="text-align: center;">Maker driving power, "Assy Lamp Code"</p> <p style="text-align: center;">Bar Code</p> </div> <p>Label of the lamp code attached on cabinet</p> <div style="display: flex; justify-content: space-around; align-items: flex-start;"> <div style="border: 1px solid black; padding: 5px; text-align: center;"> <p>Lamp Code</p> <p>ASSY LAMP CODE NO (T/O/P)</p> <p>BAR CODE</p> </div> <div style="text-align: center;"> <p>30mm</p> <p>↑</p> <p>↓</p> <p>20mm</p> <p>↑</p> <p>↓</p> <p>lamp code assy code </p> </div> </div>	<table border="1" style="width: 100%; border-collapse: collapse;"> <thead> <tr> <th style="width: 50%;">Lamp (Watt)</th> <th style="width: 50%;">Label Color</th> </tr> </thead> <tbody> <tr> <td>Lamp (Watt)</td> <td>Label Color</td> </tr> <tr> <td>1</td> <td>(WHITE)</td> </tr> <tr> <td>2</td> <td>(BLUE)</td> </tr> <tr> <td>3</td> <td>(GREEN)</td> </tr> <tr> <td>4</td> <td>(RED)</td> </tr> <tr> <td>5</td> <td></td> </tr> </tbody> </table>	Lamp (Watt)	Label Color	Lamp (Watt)	Label Color	1	(WHITE)	2	(BLUE)	3	(GREEN)	4	(RED)	5	
Lamp (Watt)	Label Color														
Lamp (Watt)	Label Color														
1	(WHITE)														
2	(BLUE)														
3	(GREEN)														
4	(RED)														
5															
<ul style="list-style-type: none"> ● How to indicate label inside (lamp) and outside a set (cabinet) <p>Outside the set (left of the cabinet of a set)</p> <p style="text-align: center;">* The left side of the cabinet</p>	<p>Inside the set (lamp bracket)</p> <p style="text-align: center;">* On the lamp shield cover inside of the set</p>														

CHECKPOINTS AND MEASURES TO TAKE WHEN CHANGING DLP A'SSYY (1/2)

1. When changing A'ssy PCB Digital

- 1) Press the button in order of Mute -> 1 -> 8 -> 2 -> Power on.
- 2) Factory item : 1. DDP1010 (All)

Item	Initial value	50 Inch	61 Inch	Description
POS - Y	16			When changing a digital board, existing data which has been adjusted get initialized. So, it may result in the shift of picture position.
POS - X	147			- When changing the Assy PCB digital, be sure to use TOS/PHILIPS for 50 inch.
Lamp	OSR	TOS/PHILS	OSR	- When changing the Assy PCB digital, the default of a lamp for 61 inch is set to OSR. Note) If lamp label is attached later, select lamp according to the color.
Delay	223			When changing a digital board, existing data which has been adjusted get initialized. So, it may result in the shift of picture position.
V-FLIP	Normal			
H-FLIP	Normal			
GAMMA	4			

2. DNle (All) :

- 1) When changing the Assy PCB digital, the items below change to a certain value so it is necessary to check the state of the screen.

Item	Initial value	Description
R-GAIN	120	Do re-adjustment when high light zone has a difference in color.
G-GAIN	120	Fixed
B-GAIN	120	Perform re-adjustment when high light has a difference in color.
R-OFFSET	128	Do re-adjustment when low light zone has a difference in color.
G-OFFSET	128	Fixed
B-OFFSET	128	Do re-adjustment when low light zone has a difference in color.
S_CT	Difference by Input Mode	RF:135 / DTV:118 / DVI:112(NOW:106) / PC:107

- 2) Above items are easy to adjust if you set the color of Factory option to Off.

CHECKPOINTS AND MEASURES TO TAKE WHEN CHANGING DLP ASSY (2/2)

2. When changing Engine

1) Factory item :

1. DDP1010 Delay

Item	Initial value	Description
POS - Y	16	The position of picture may be shifted depending on the state of engine.
POS - X	147	
DELAY	223	When changing a color wheel attached on the engine, color may change due to the deviation of where color wheel sensor is assembled.

2. R,G Gain and R,B Offset of Dnle items is needed to adjust if the screen has a problem.

8. Option items

Item	Initial value	Description
lamp life	0	When changing lamp, set the value to "0".
lamp clear		Make the data clear and then lamp life "0" hour.

3. When changing Color Wheel

1. Do adjustment for Delay of DDP1010 if it has a difference in Red.

Item	Initial value	Description
Delay	223	When color wheel is changed the same case as engine, color may change due to the deviation of where color wheel is assembled.

4. When changing Lamp, clear the lamp life on 8. Option item. For defective lamp, write in a defect form with the time used.

Item	Initial value	Description
lamp life	0	When changing lamp, set the value to "0".
lamp clear		Make the data clear and then lamp life "0" hour.

5-8 Lens and Mirror Cleaning

1. Mix the alcohol and ethyl in appropriate proportions.
2. Use a clean cotton cloth or a cleaning paper.
3. Clean the top of the lens by turning it as shown. The pattern starts at the center and proceeds outward, as shown below:

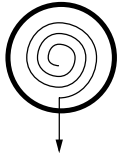

4. Use minimal pressure when rubbing the mirror. Otherwise, the surface will be damaged.

5-9 Focus Adjustment for projection Lens

1. Input the Cross hatch pattern or lion head pattern from the pattern generator.
2. Lift up the Focus Cover in the Optical Engine. (Fig. 1)
3. Move the focus adjustment dial to the clockwise or counter clockwise until the picture is clearly displayed. (Fig. 2)
4. Reposition the Focus Cover in the Optical Engine. (Fig. 3)
5. Check the focus adjustment.
6. Repeat adjustment 1~5, If necessary.

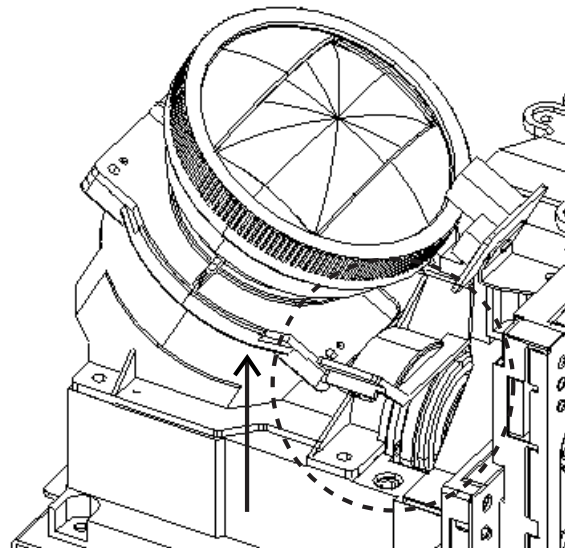

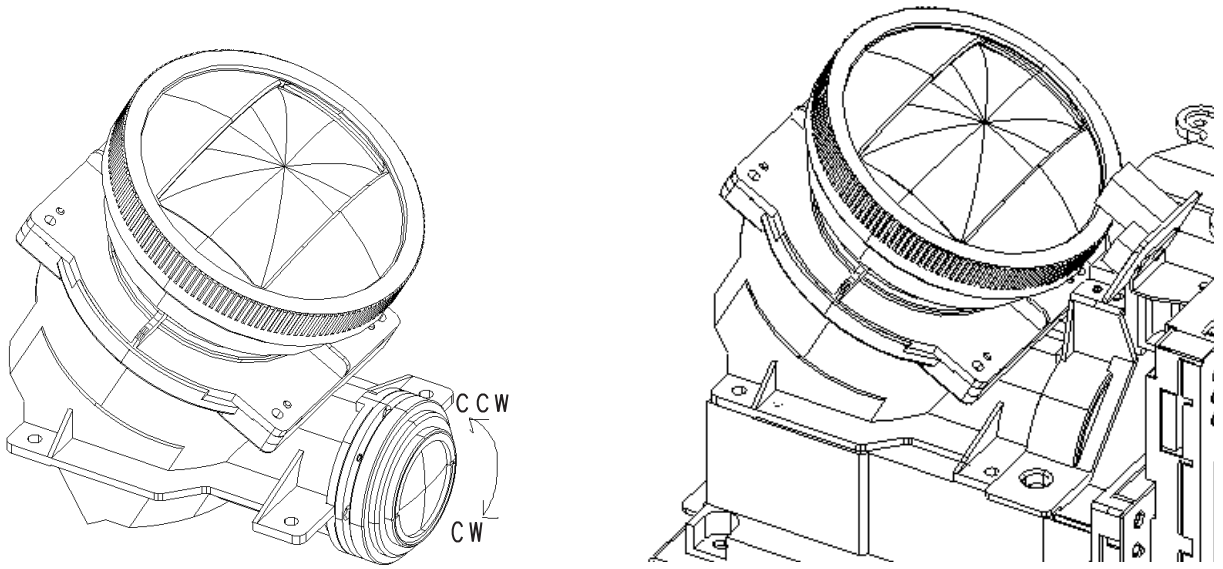

5-10 Engine Service Method

5-10-1 Lamp replacement Method

■ Lamp replacement

- 1) Failure type : The screen is dark due to low brightness.
The lamp does not operate.
- 2) Reference drawings: Refer to Service Manual.

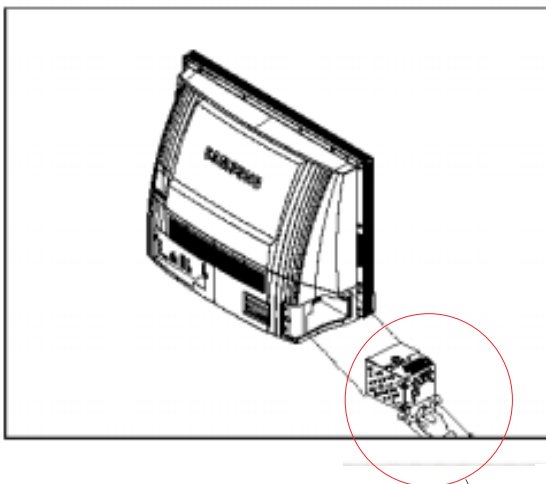
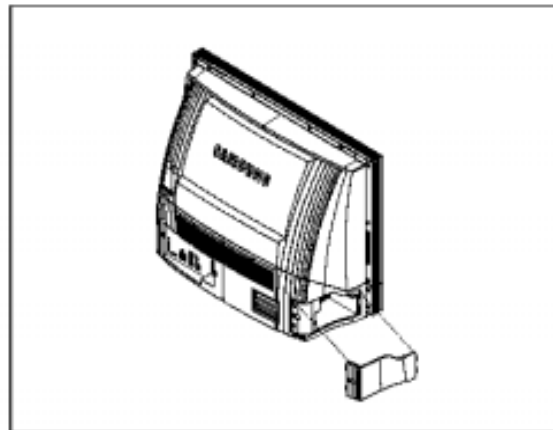
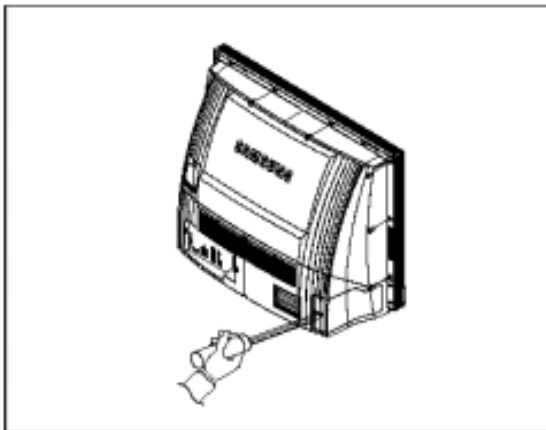

■ Lamp replacement Method

0. Place the set on a flat, wide space.
(If the set is placed on an uneven space, the lamp may not be well fitted during replacement.)
1. Remove one screw on the right side of the back.
2. Remove the lamp door.
3. Loosen the two screws which hold the lamp in place.
(The screws can be loosened but cannot be removed.)
4. Hold the knob of the lamp and pull it out.
5. Re-assemble with a new lamp in the reverse order.

ASS'Y CODE :

*43"와 50" TOSHIBA LAMP--

*61" OSRAM LAMP -----

5-10-2 BALLAST replacement Method

< Failure type : The lamp does not operate.

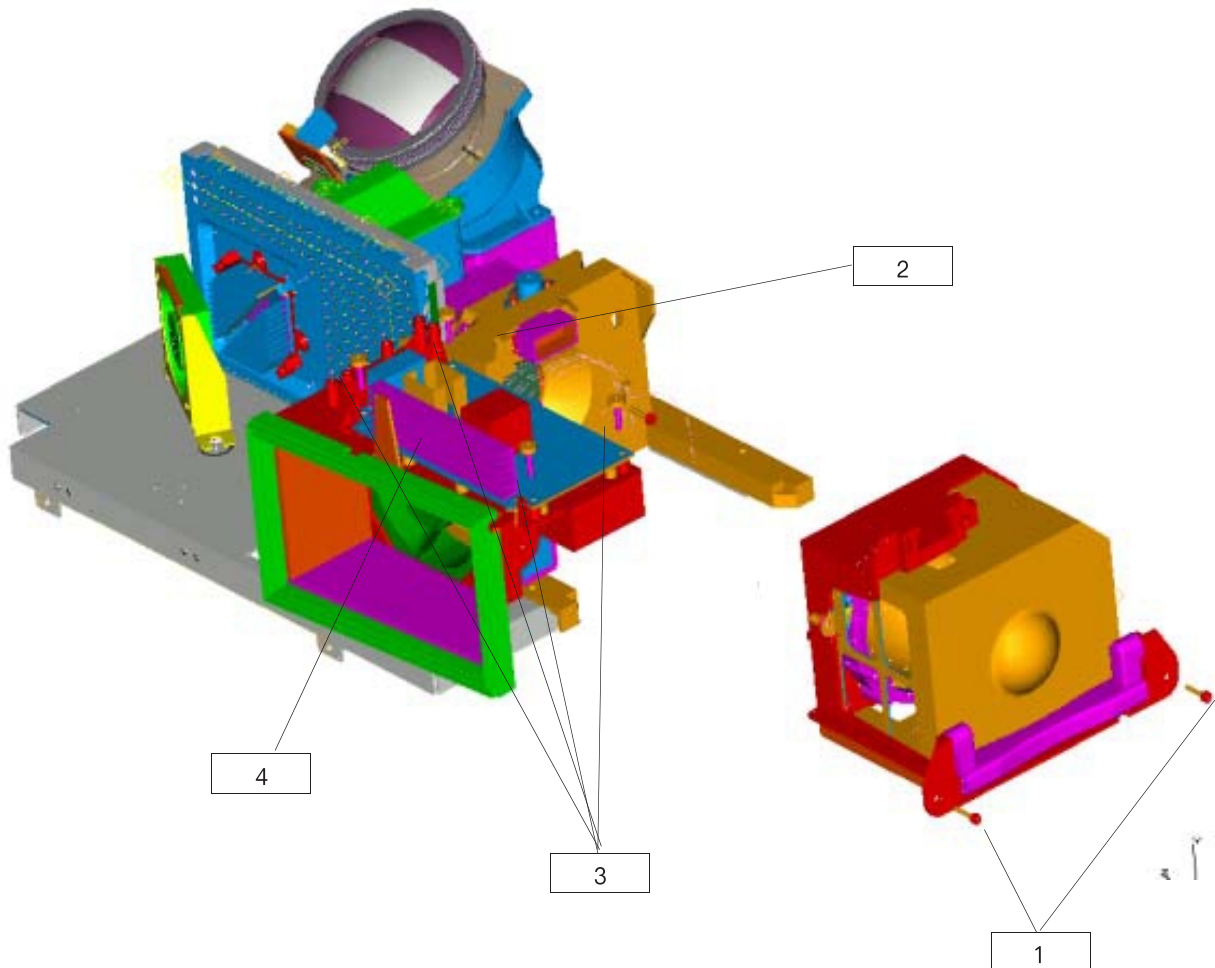

1. Loosen the two screws which hold the lamp in place, and then remove the lamp.
2. Loosen the screw which holds the connector in place.
3. Loosen the four screws on the ballast board.
4. Replace it with a new board and re-assemble it in the reverse order.

5-10-3 Color Wheel : When wheel noise occurs.

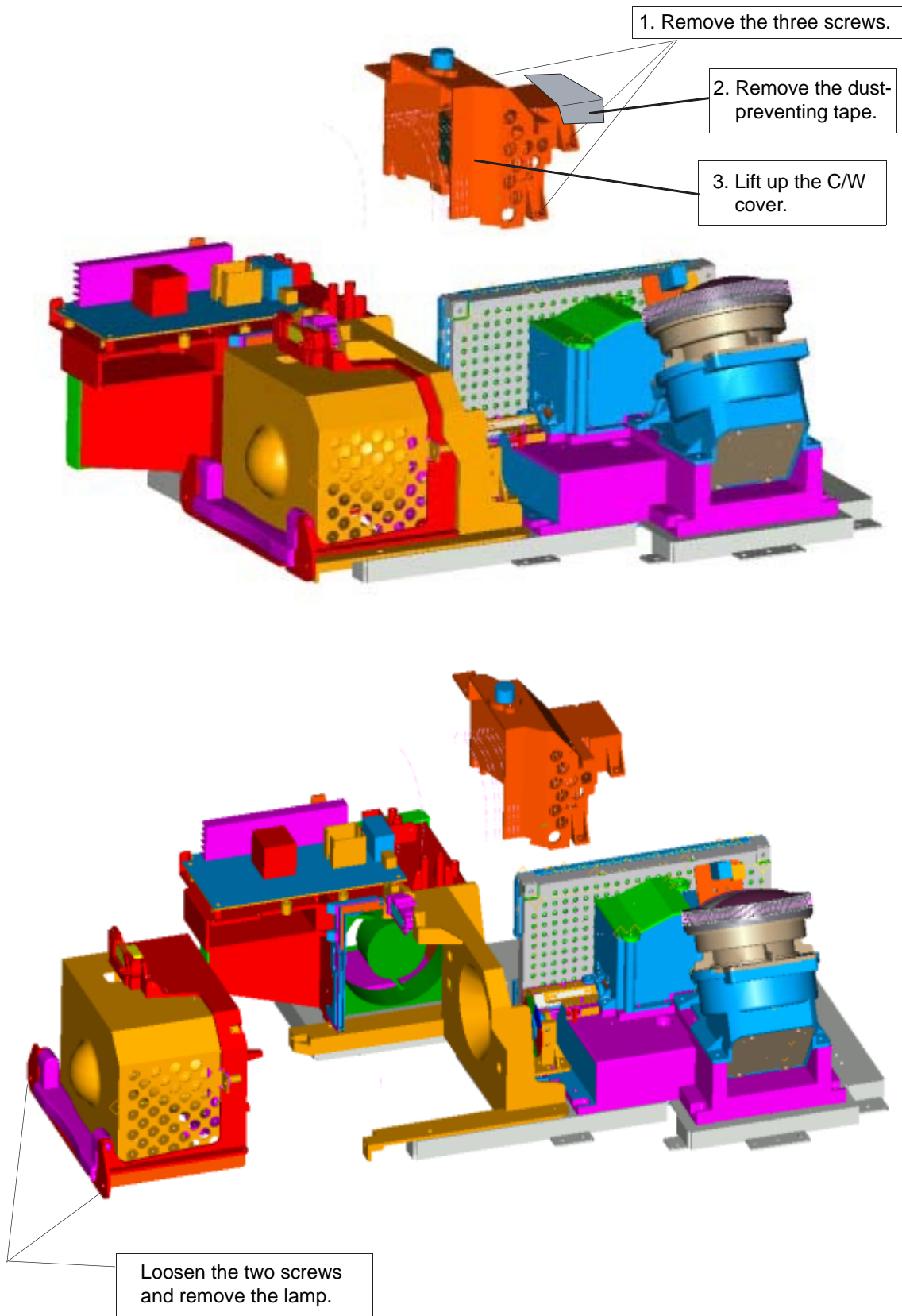

Remove the five screws.
Lift up the bracket and the light tunnel.
※ Be careful not to dirty the light tunnel with foreign materials.

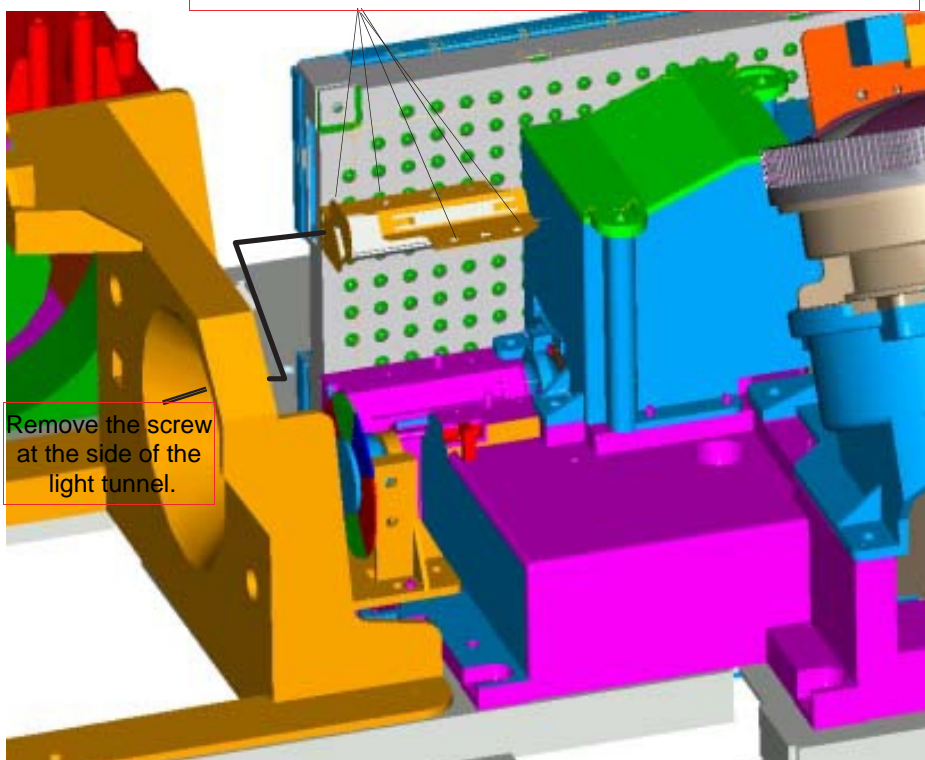

Remove the screw
at the side of the
light tunnel.

Remove the three screws
and replace the
color wheel ASSY.

* Caution: Never touch the color wheel.
Touch only the instruments.

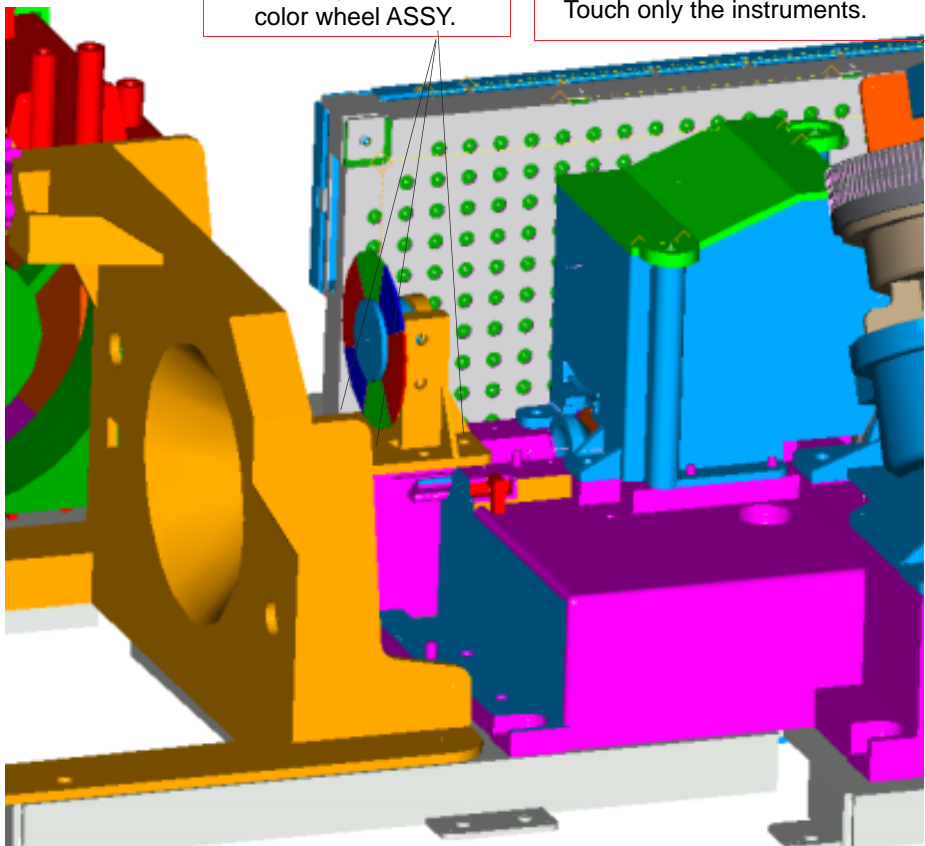

5-10-4 Screen Tilt : When the screen tilts, or the image position deviates.

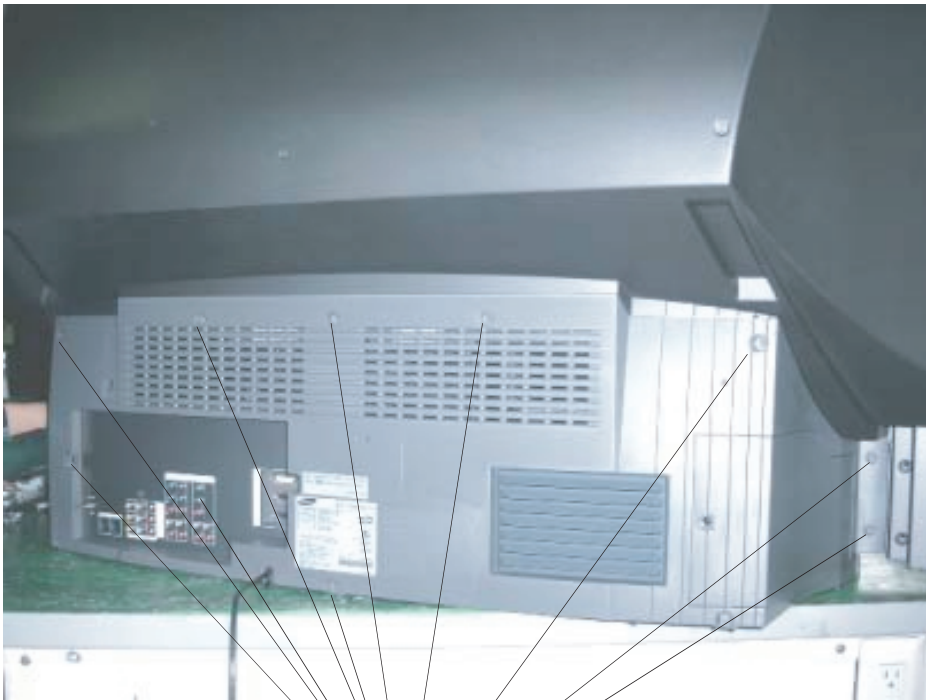

Remove the bottom cover.



Remove the cover of the signal terminal.

Fix the safety switch on the right with tape so that the set can be turned on after removing the bottom cover.

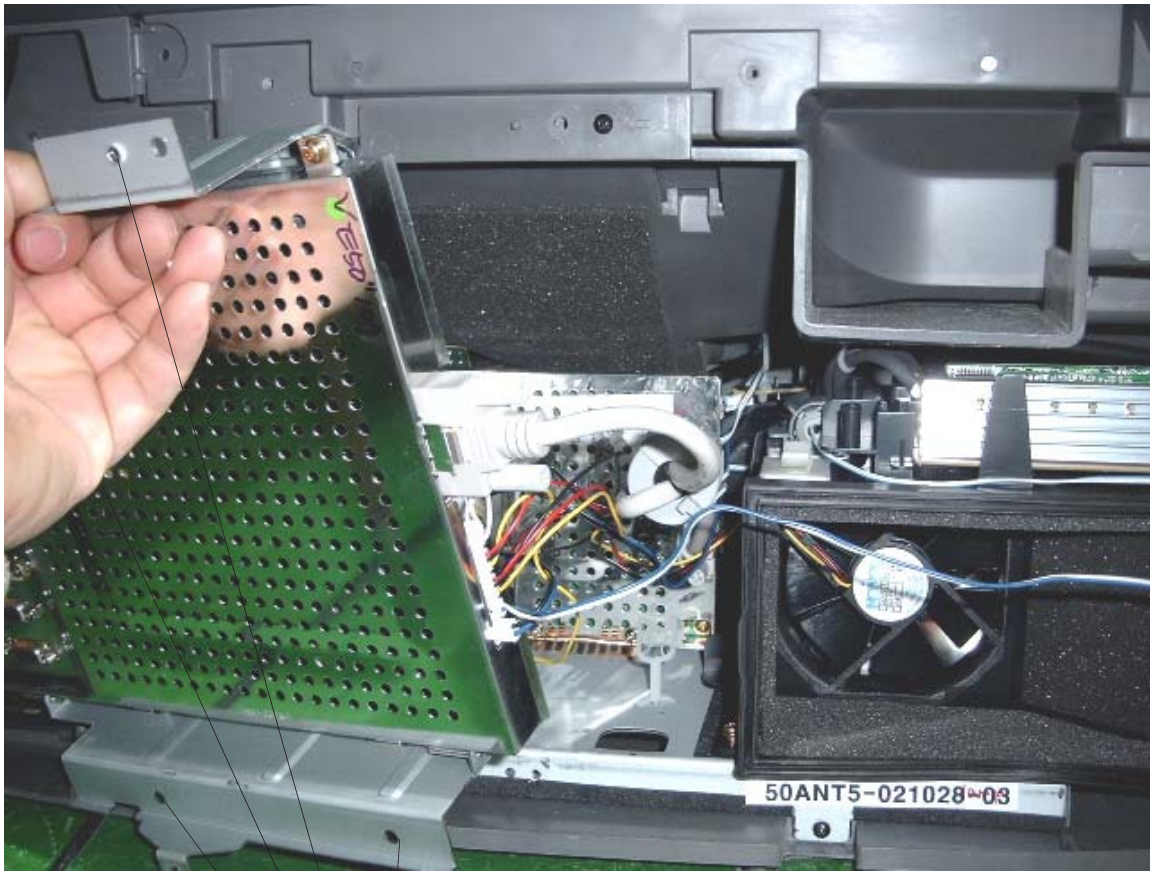

Remove the four screws on the upper and lower part of the digital board bracket, and remove the whole assembly without removing the cable.

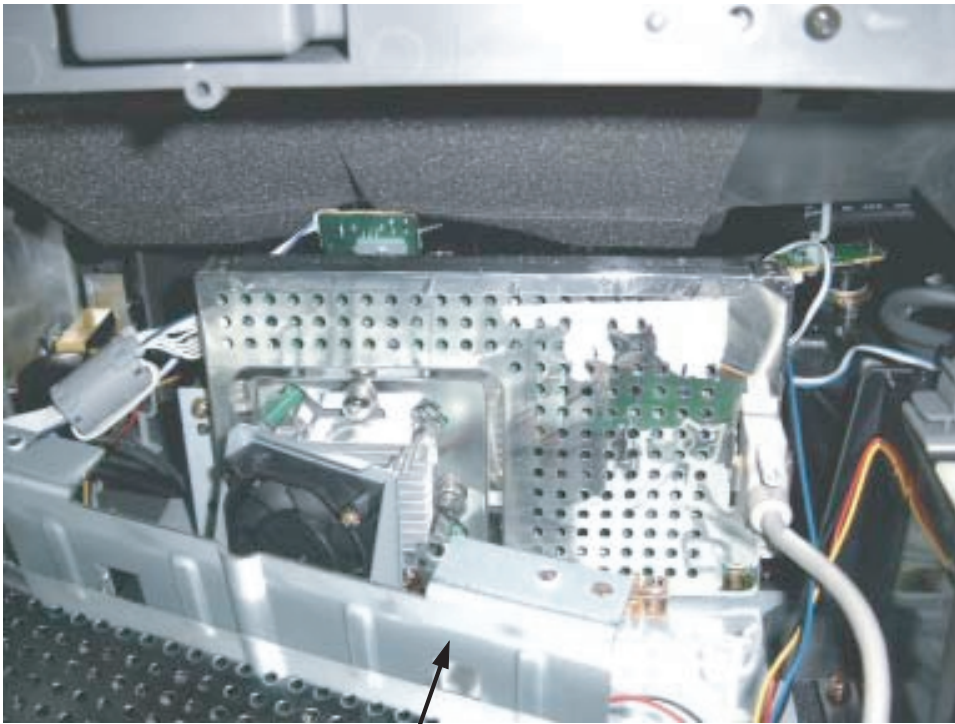

Place the digital board and the bracket on the back, and keep the cables connected.

Fix the safety switch on the right with tape so that the set can be turned on after removing the bottom cover.



Remove the two screws on the left and the one screw on the bottom right, without removing the engine.
* Even when those screws are removed, the board does not separate, it can be moved within the adjustable range because there is a spring screw at the center that holds it.

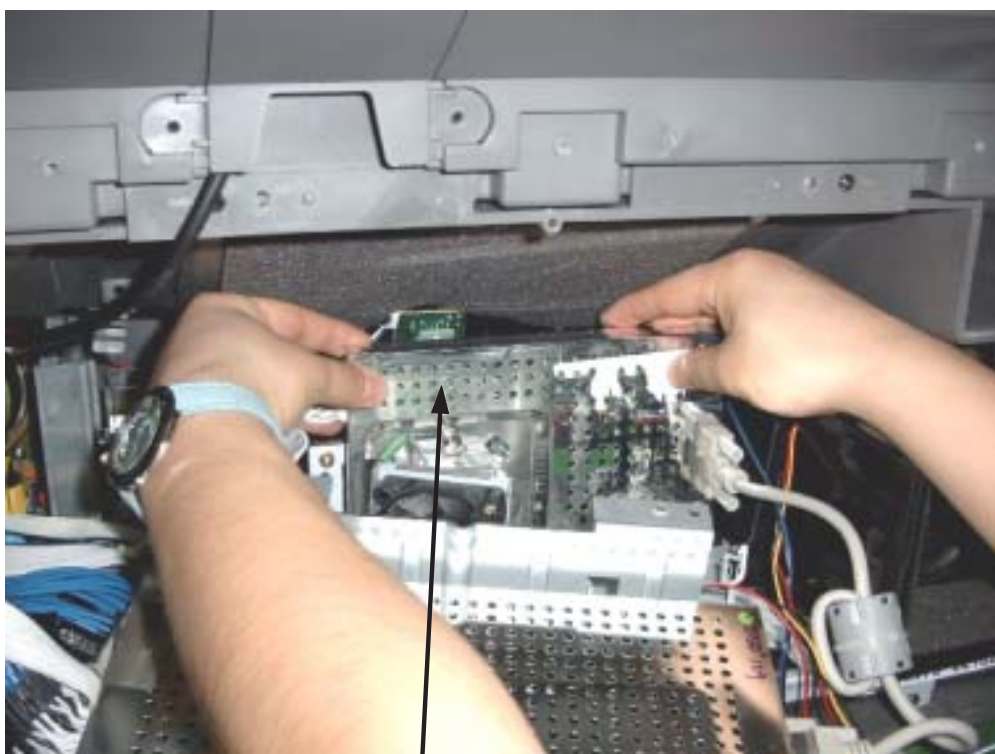

Turn on the TV to send signals.
Then, adjust the screen position,
by holding both of the upper corners
of the DMD board.

✧ When adjusting the screen, it is better for two people to work together.
One person should direct the picture position while the other person looks
at the screen.

✧ The movement direction of the board and the picture are opposite.
- When the board is lifted upward, the screen descends down.
- When it is tilted to the left, the screen tilts to the right.

✧ When the picture adjustment is completed:
First, tighten the two screws on the left of the DMD board
and then slowly tighten the one screw on the bottom right.
Be careful not to touch the board while screwing.
(When using an electric-powered screwdriver, be careful that
the torque is not too high.)

5-10-5 Failure that occurs when the vertical line or the raster is skipped: Always, make sure to replace the DMD board.

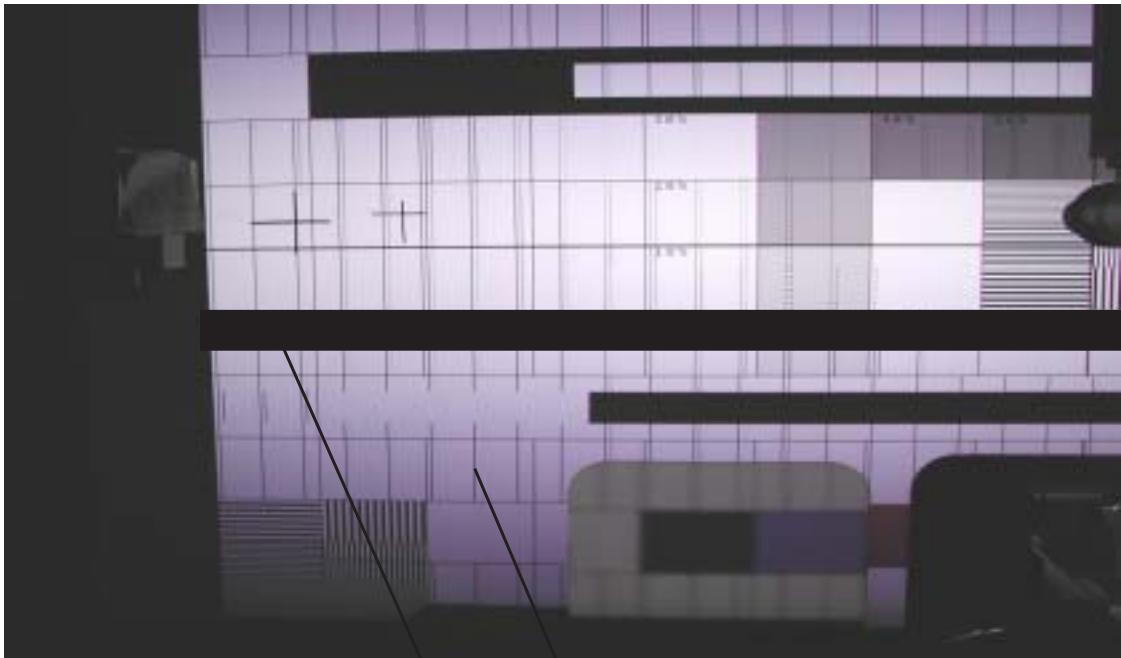

White or Black
VERTICAL LINE

HORIZONTAL Black Bar

< Service Method >

1



2



Remove the two screws on the left and the one screw on the bottom right, without removing the engine.
 ※ When those screws are removed, the board will not separate. It can be moved within the adjustable range because there are spring screws in the center area which hold it.

3



Remove the three spring screws at the center area completely.

※ After replacing it with a new DMD board, tighten screw spring #3 using weak power (below 8kgf). Then, lightly tighten screws #1 and #2 without tightening them completely.

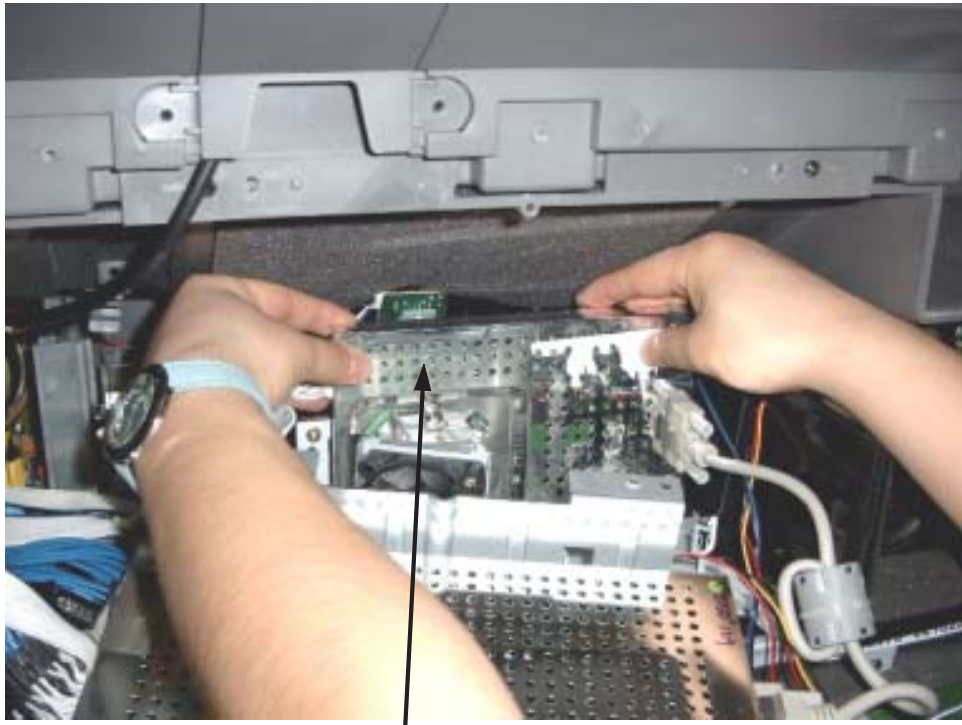

After assembling the engine into the set, connect the cables and then perform the same procedures for screen tilt adjustment.



✳ When the adjustment is completed, assemble it by half, as shown in the figure, and re-check the picture position. If there is no problem, assemble the bottom cover and tighten the screws.

5-10-6 Foreign Material Failure: Foreign material appears on the screen like a rainbow with pink and pale green streaks.

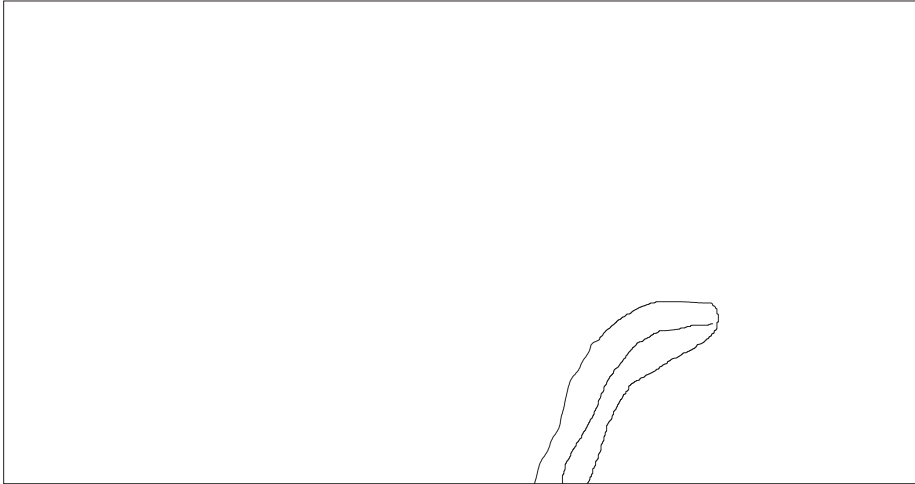

< Service Method >

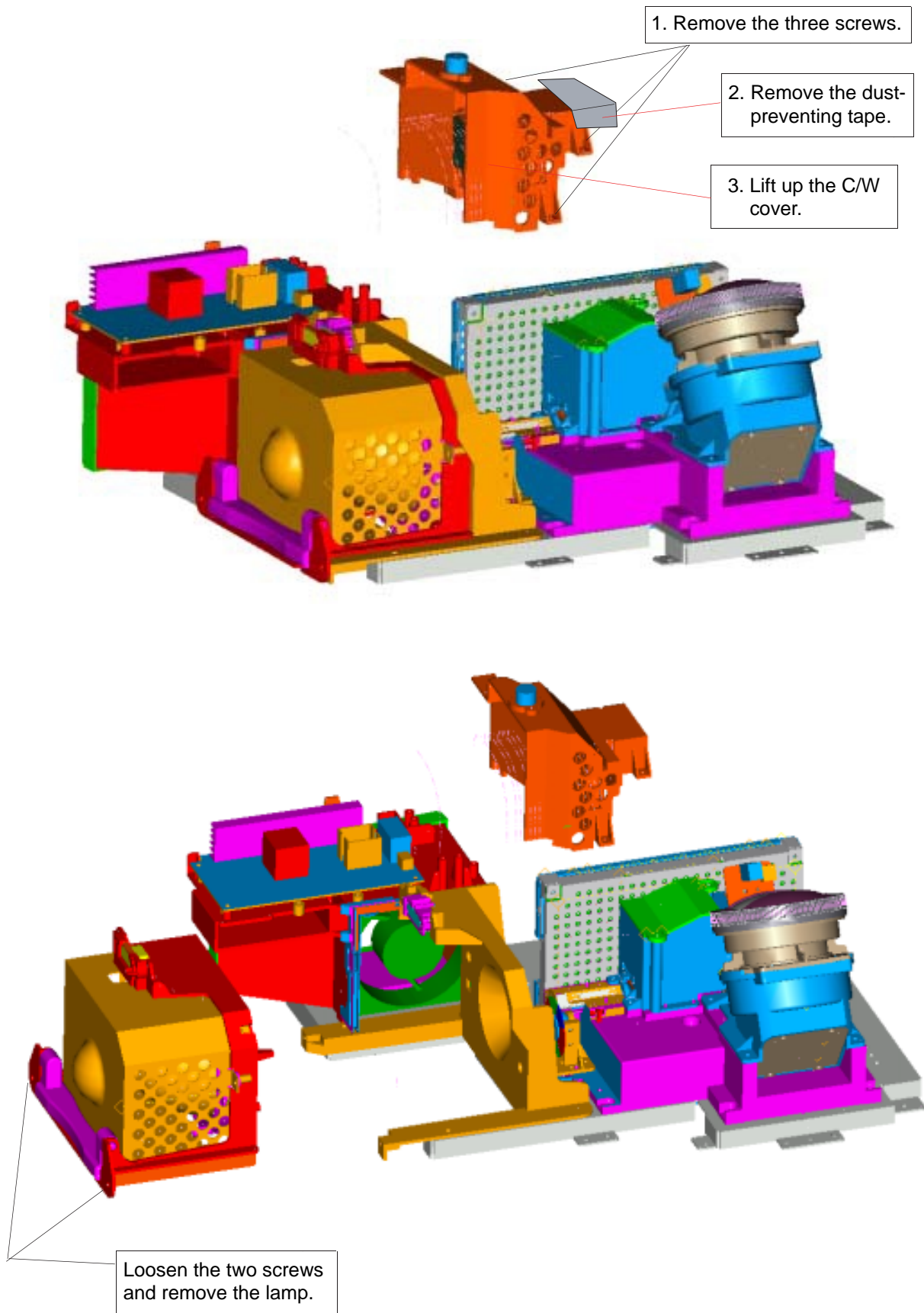

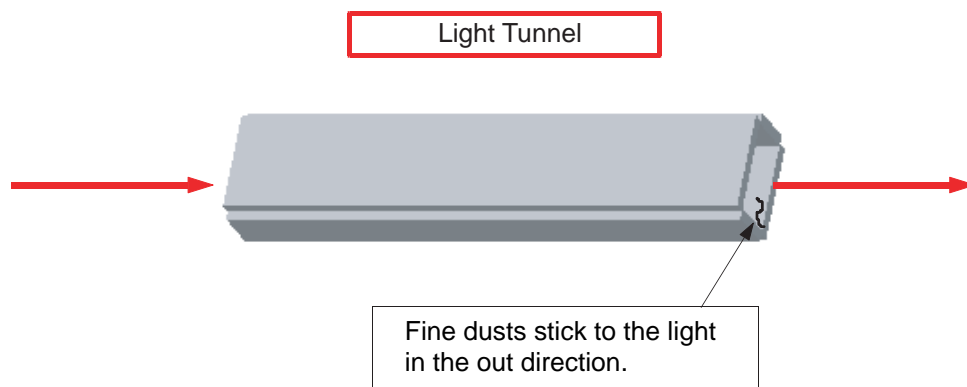
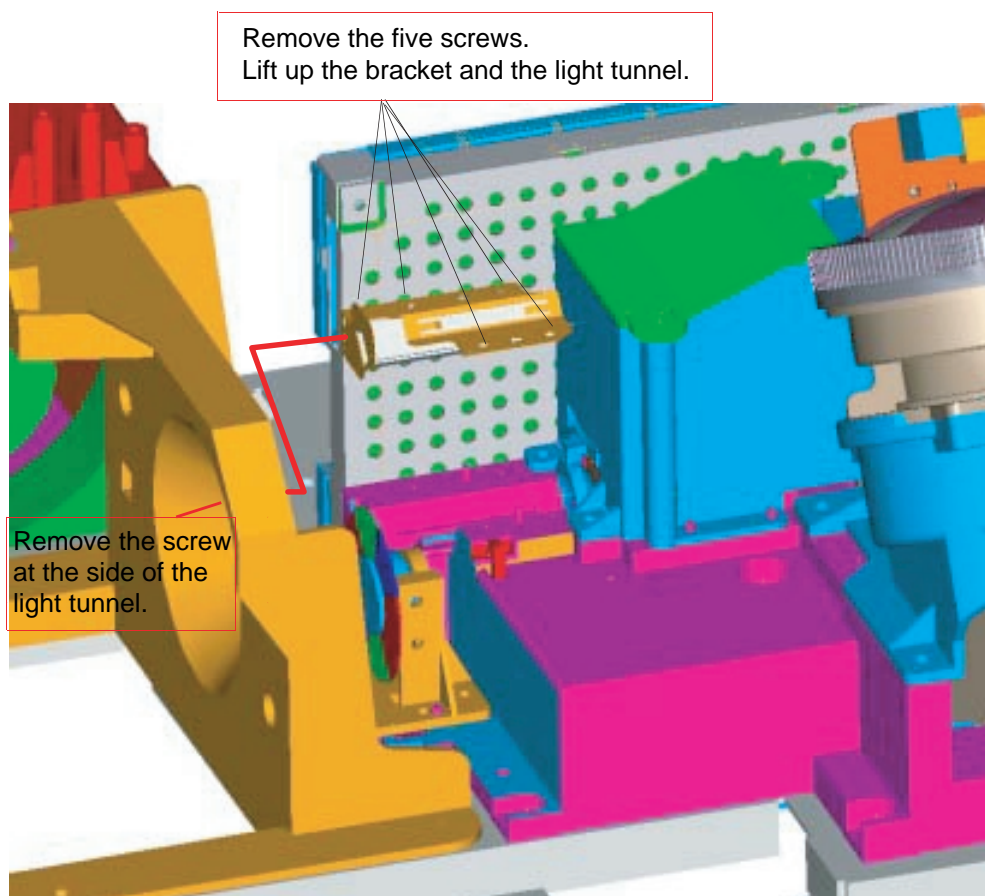

- * Blow out the dust with strong bursts of air, and then re-assemble in reverse order. Make sure to work in a clean room to avoid dust getting in again.
- * Since the existing dust might not be completely cleared, change the direction of the light tunnel after cleaning with bursts of air.
 - Switch the light input part to the output part, and the light output part to the input part, on a 180 degree angle.
 - This failure can occur only when there is dust on the output part. Any dust on the input parts are extinguished by heat
- * Re-assemble the ASSY in reverse order.

5-10-7 Servicing Material Classification

1. LAMP ASSY



- 1) Toshiba lamp 43" and 50" in common - Serial number is marked FXXXXXXXX on the marking area.
- 2) OSRAM 61" - Only 61" is marked on the marking area.

2. COLOR WHEEL ASSY



- 1) COLOR WHEEL
- 2) HOLDER (MOLD)
- 3) SENSOR PCB
- 4) SENSOR CABLE
- 5) COLOR WHEEL SIGNAL CABLE

3. DMD ASSY



4. 92 x 92 FAN ASSY FAN + SQUARE RUBBER

5-11 Side Panel Buttons

The buttons on the side panel control your TV's basic features, including the on-screen menu system. To use the more advanced features, you must use the remote control.

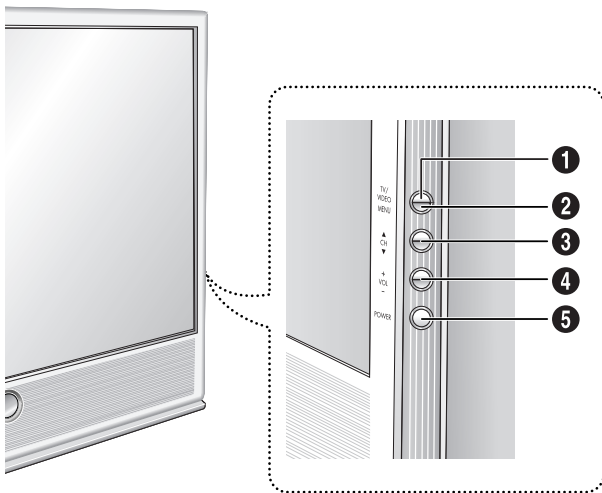

▲ HLM437W/HLM507W/HLM617W

1 TV/Video

Press to switch between viewing TV programs and signals from connected components.

2 Menu

Press to see the on-screen menu.

3 ▼ Channel ▲

Press to channels and move between items on the on-screen menu.

4 Volume +, -

Press to lower or raise the volume and to select items when using the on-screen menu.

5 Power

Press to turn the TV on and off.

- To select an external source signal with using the TV/Video button on the side panel, (1) Press the TV/Video button, (2) use the channel up/down buttons to move to source signal that you prefer, and (3) press the volume +/- buttons to select it.

(Note : To select an external source signal with using the TV/Video button on the remote control , use the joystick button to select the source signal that you prefer)

5-12 Side Panel Jacks

Use the side panel jacks to connect a component that is used only occasionally (a camcorder, video game or PC, for example) .

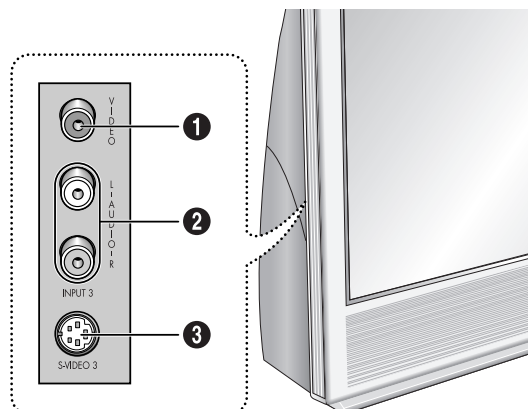

▲ HLM437W

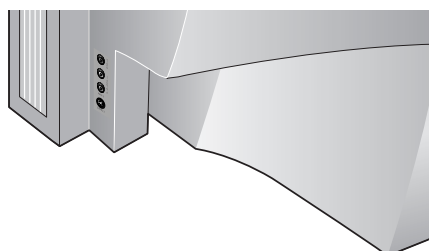

◀ HLM507W/HLM617W

1 VIDEO INPUT JACK

Connect the video signal from a camcorder or video game.

2 AUDIO INPUT JACKS

Connect the audio signal from a camcorder or video game.

3 S-VIDEO INPUT JACK

Connect an S-video signal from a camcorder or video game. (S-Video 3 jack and Audio L/R input 3 are used in conjunction.)

5-13 Side Panel Buttons

The buttons on the side panel control your TV's basic features, including the on-screen menu system. To use the more advanced features, you must use the remote control.



▲ HLM4365W/HLM5065W

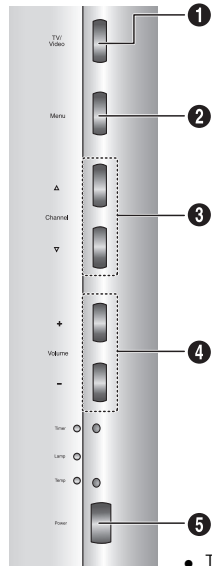

1 TV/Video

Press to switch between viewing TV programs and signals from connected components.

2 Menu

Press to see the on-screen menu.

3 ▼ Channel ▲

Press to channels and move between items on the on-screen menu.

4 Volume +, -

Press to lower or raise the volume and to select items when using the on-screen menu.

5 Power

Press to turn the TV on and off.

- To select an external source signal with using the TV/Video button on the side panel, (1) Press the TV/Video button, (2) use the channel up/down buttons to move to source signal that you prefer, and (3) press the volume +/- buttons to select it.

(Note : To select an external source signal with using the TV/Video button on the remote control , use the joystick button to select the source signal that you prefer)

5-14 Side Panel Jacks

Use the side panel jacks to connect a component that is used only occasionally (a camcorder, video game or PC, for example) .

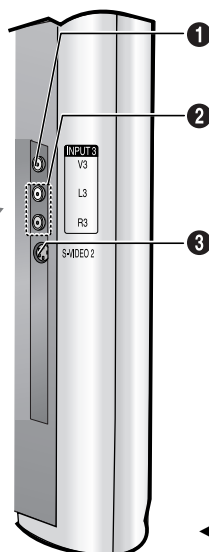
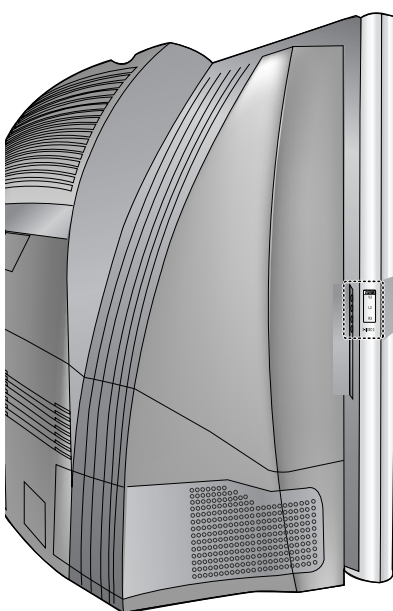

◀ HLM4365W/HLM5065W

1 VIDEO INPUT JACK

Connect the video signal from a camcorder or video game.

2 AUDIO INPUT JACKS

Connect the audio signal from a camcorder or video game.

3 S-VIDEO INPUT JACK

Connect an S-video signal from a camcorder or video game. (S-Video 3 jack and Audio L/R input 3 are used in conjunction.)

5-15 Rear Panel Jacks

Use the rear panel jacks to connect components such as a VCR. You can connect two different components such as two VCRs, a Set-Top Box and a DVD player etc., because there are two sets of video input jacks and one set of component video input jacks on the rearpanel of your TV. For more information, please see "Connections".

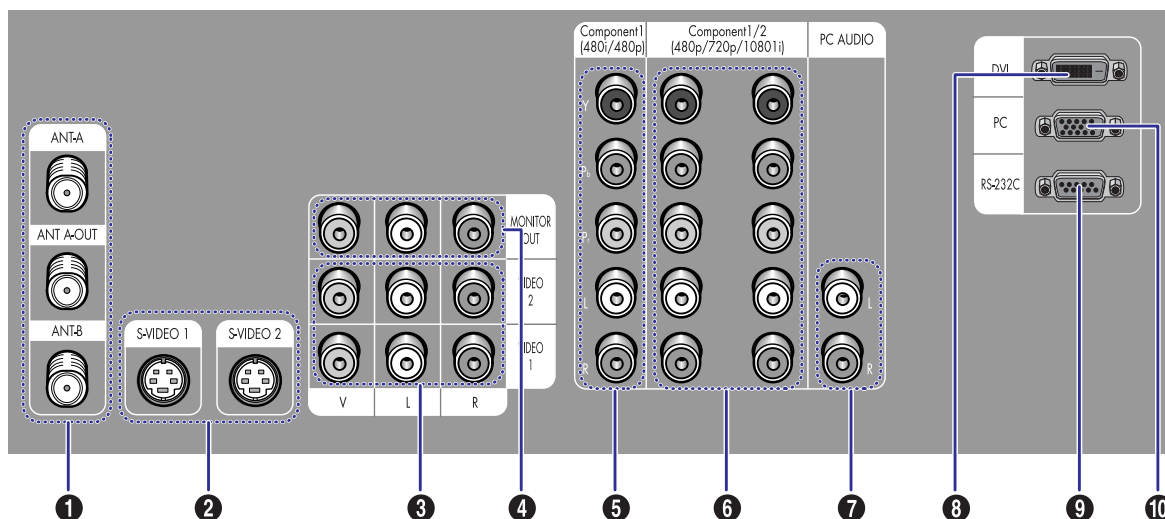

1 ANTENNA terminals

Two independent cables or antennas can be connected to these terminals. Use ANT-A and ANT-B terminals to receive a signal from VHF/UHF antennas or your cable system. Use the ANT-A OUT terminal to send the signal being received by the ANT-A terminal out to another component (such as a Cable Set Top Box).

The PIP channel can be received only when a signal source is connected to ANT-A.

2 S-VIDEO INPUT jacks

Connects an S-Video signal from an S-VHS VCR or DVD player.

3 VIDEO/AUDIO INPUT jacks(VCR1, VCR2)

Connect video/audio signals from external sources, such as a VCR or DVD players.

4 VIDEO/AUDIO MONITOR OUT jacks

Sends a video signal from the TV to an external source, such as a VCR.

Note: Monitor Out is available only in RF, Video and S-Video modes.

5 COMPONENT1 jacks (Y, Pb, Pr, L, R)

Use these jacks to connect the component video/audio signals from a DVD player when using the component video input jacks.

Note: Only 480i and 480p formats are supported.

6 Component 2, 3 jacks (Y, Pb, Pr, L, R)

Receives the DTV video/audio signals from a set top box.

Note: Only 480p, 720p and 1080i formats are supported.

7 PC AUDIO INPUT jacks

Connect these to the audio-output jacks on your PC.

8 DVI (Digital Video Interface) jack

Receives the digital signals from a set top box or PC etc.

9 RS-232C jack

This jack is used for the service personnel.

10 PC VIDEO INPUT jack

Connect to the video output port on your PC.

5-16 LED Display Check

The three lights on the side panel indicate the status of your TV.

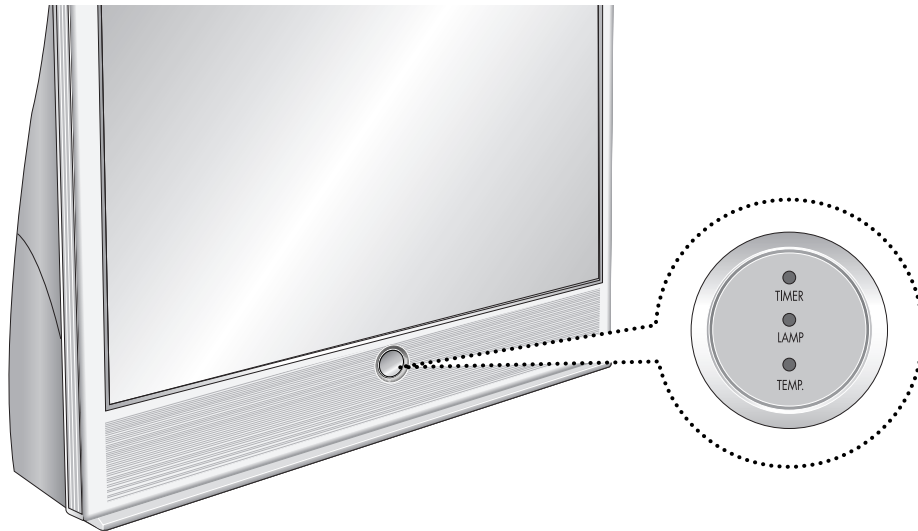

▲ HLM437W/HLM507W/HLM617W

Indicator Light Key

- : Light is On
- ◐ : Light is Blinking
- : Light is Off

Timer	Lamp	Temp	Indication
●	○	○	Auto Timer ON/OFF has been set.
○	●	○	The set is operating normally.
○	◐	○	Standby state. The picture will automatically appear in about 25 seconds.
●	●	○	Auto Timer ON/OFF has been set and the set is normally operating.
●	◐	○	Auto Time ON/OFF has been set and the set will automatically be turned on in about 25 seconds.
◐	○	◐	A cooling fan inside the set is not operating normally.
○	◐	◐	Lamp cover on rear of the set is not properly shut.
○	○	◐	Check if the ventilation hole on the rear of the set is blocked, because if the inner temperature is too high, the power will shut off.
◐	◐	◐	Lamp doesn't light. It may have a fault or has burned out. Replace with a new lamp.

- It takes about 30 seconds for the TV to warm up, so normal brightness may not appear immediately.
- The TV has a fan to keep the inside lamp from overheating. You'll occasionally hear it working.

The three lights on the side panel indicate the status of your TV.

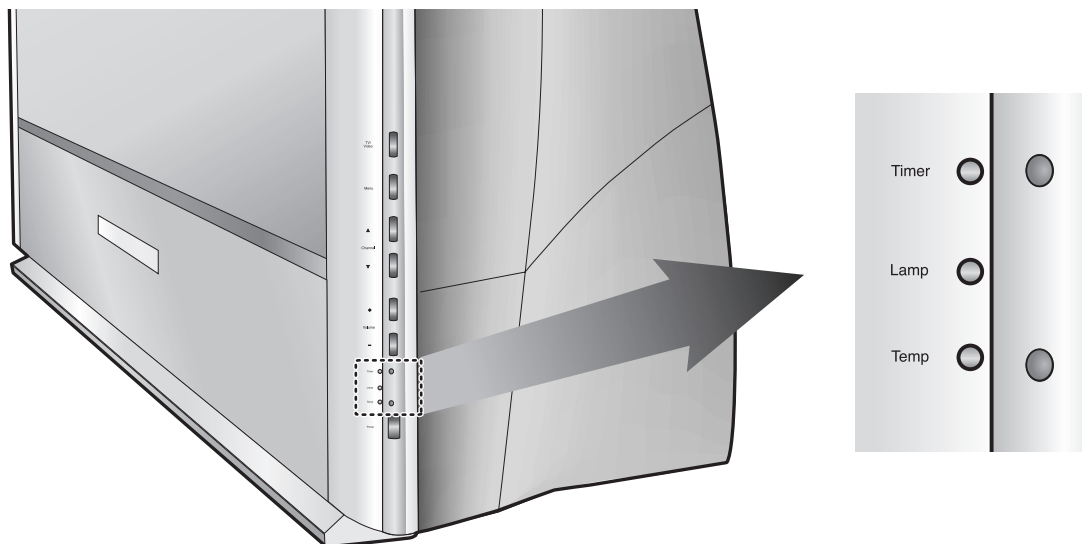

▲ HLM4365W/HLM5065W

Indicator Light Key

- : Light is On
- ◐ : Light is Blinking
- : Light is Off

Timer	Lamp	Temp	Indication
●	○	○	Auto Timer ON/OFF has been set.
○	●	○	The set is operating normally.
○	◐	○	Standby state. The picture will automatically appear in about 25 seconds.
●	●	○	Auto Timer ON/OFF has been set and the set is normally operating.
●	◐	○	Auto Time ON/OFF has been set and the set will automatically be turned on in about 25 seconds.
◐	○	◐	A cooling fan inside the set is not operating normally.
○	◐	◐	Lamp cover on rear of the set is not properly shut.
○	○	◐	Check if the ventilation hole on the rear of the set is blocked, because if the inner temperature is too high, the power will shut off.
◐	◐	◐	Lamp doesn't light. It may have a fault or has burned out. Replace with a new lamp.

- It takes about 30 seconds for the TV to warm up, so normal brightness may not appear immediately.
- The TV has a fan to keep the inside lamp from overheating. You'll occasionally hear it working.

5-17 Remote Control

You can use the remote control up to a distance of about 23 feet from the TV. When using the remote, always point it directly at the TV. The remote control can also operate your VCR, cable box, and DVD player.

1. POWER

turns the TV on and off.

2. +100

Press to select cable channels over 100 on TV.

3. Menu

Displays the main on-screen menu.

4. CH(Channel) and VOL (Volume)

Controls volume, channel selection.

5. Mute

Press to mute the TV sound.

6. Display

Press to display information on the TV screen.

7. Aspect

Press to change the screen size.

8. Surround

Press to hear the Dolby surround effect.

9. MTS(Multichannel Television Stereo)

Press to choose stereo, mono or Separate Audio Program (SAP broadcast).

10. Mode

Selects a target device to be controlled by the Samsung remote control. (i.e., TV, VCR, Cable, or DVD)

11. Pre-ch

Tunes to the previous channel.

12. TV/Video

Press to display all of the available video sources. (i.e., TV, VCR, DVD, DTV, PC)

13. Joystick

Use to highlight on-screen menu items and change menu values.

14. DNle

Activates DNle (Digital Natural Image engine)

15. PIP

Activates picture in picture.

16. Still

Press to stop the action during a particular scene. Press again to resume normal video.

17. Fav.CH (Favorite Channel)

Press to switch between your favorite channels.

18. S.Mode

Adjust the TV sound by selecting one of the preset factory settings (or select your personal, customized picture setting.)

19. P.Mode

Adjust the TV picture by selecting one of the preset factory settings (or select your personal, customized picture setting.)

20. VCR controls

Controls VCR tape functions. Rewind, Play, Fast Forward, Stop, Pause.

21. PIP controls

Source: Press to select one of the available signal sources for the PIP window.

Scan: Press to scan the memorized channels.

Locate: Press to move the PIP window to any of the four corners of the TV screen.

Swap: Exchanges the video signal that is currently displayed on the main screen with the signal in the PIP window.

Size: Press to make the PIP window larger or smaller.

CH(PIP): Displays the available channels in sequence. (These buttons change channels in the PIP window only.)

22. V.chip

Press to set up and activate the parental locks.

23. Set

Used during set up of this remote control, so that it will work compatibly with other devices. (VCR, cable box, DVD, etc.)

24. Sleep

Press to select a preset time interval for automatic shutdown.

25. Add/Erase

Press to add or erase channels in the TV's memory. Use the Add/Erase button to memorize/erase the fine tuning after fine tuning channels.

